

DC Centrifugal Fan Forward Curved $\text{\O}180 \times 126 \text{mm}$

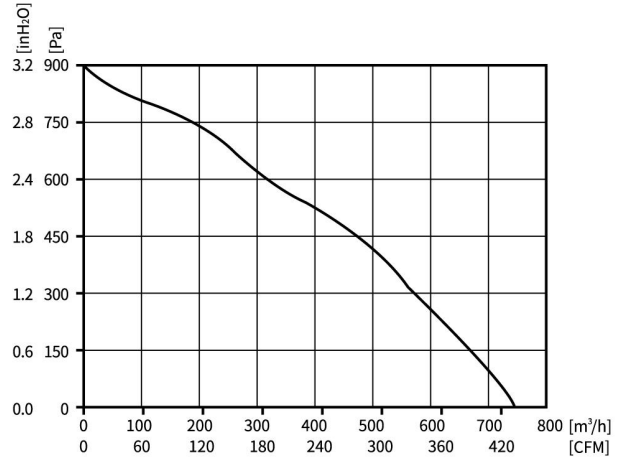

Forward Curved Centrifugal Fans

| | | | | | | |
|---|-------------------------------|-------------------------|-----------------------|--|-----------------|-------------------|
| Motor Type DC BRUSHLESS EXTERNAL ROTOR MOTOR | Speed Control 0-10VVDC/PWM | Protection Type IP55 | Insulation Class B | Operating Temperature -25°C ~ +60°C | Weight 1.8KG | Wiring Mode D1 |
|---|-------------------------------|-------------------------|-----------------------|--|-----------------|-------------------|

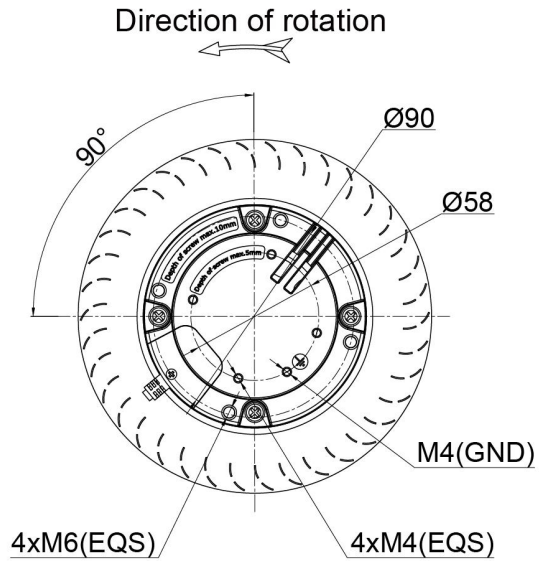
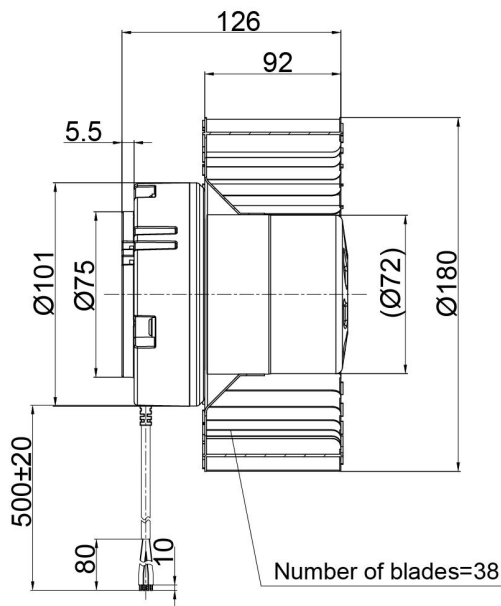

| Model | Motor | Bearing System | Rated Voltage | Operating Voltage | Rated Current | Rated Power | Rated Speed | Air Flow | Air Pressure | Sound Level |
|----------------|--------|----------------|---------------|-------------------|---------------|-------------|-------------|-------------------|--------------|-------------|
| Part No. | Type | B/S | VDC | VDC | A | W | RPM | M ³ /H | Pa | dB(A) |
| PF3N180B24-TZ0 | BE72DC | BALL | 24 | 16~28 | 5.2 | 124.8 | 1350 | 740 | 900 | 66 |
| PF3N180B48-TZ0 | BE72DC | BALL | 48 | 36~57 | 2.6 | 124.8 | 1350 | 740 | 900 | 66 |

DC Centrifugal Fan Forward Curved Ø120x84mm

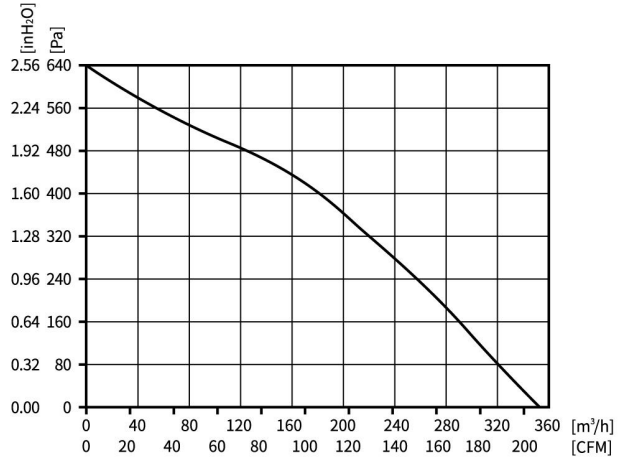

| | | | | | | |
|---|-------------------------------|-------------------------|-----------------------|--|------------------|-------------------|
| Motor Type DC BRUSHLESS EXTERNAL ROTOR MOTOR | Speed Control 0-10VVDC/PWM | Protection Type IP55 | Insulation Class B | Operating Temperature -25°C ~ +60°C | Weight 1.05KG | Wiring Mode D1 |
|---|-------------------------------|-------------------------|-----------------------|--|------------------|-------------------|

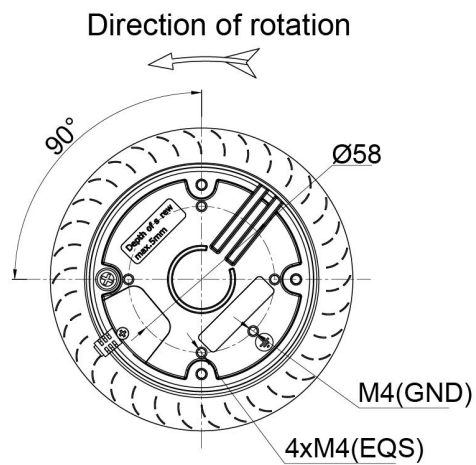
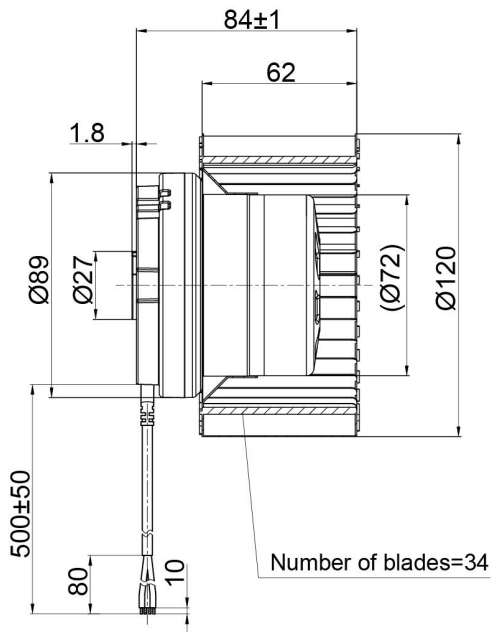

Forward Curved Centrifugal Fans

| Model | Motor | Bearing System | Rated Voltage | Operating Voltage | Rated Current | Rated Power | Rated Speed | Air Flow | Air Pressure | Sound Level |
|----------------|--------|----------------|---------------|-------------------|---------------|-------------|-------------|-------------------|--------------|-------------|
| Part No. | Type | B/S | VDC | VDC | A | W | RPM | M ³ /H | Pa | dB(A) |
| PF3N120B24-RZ0 | BE72DC | BALL | 24 | 16~28 | 2.8 | 67.2 | 2400 | 350 | 640 | 67 |
| PF3N120B48-RZ0 | BE72DC | BALL | 48 | 36~57 | 1.4 | 67.2 | 2400 | 350 | 640 | 67 |

DC Centrifugal Fan Forward Curved Ø140x72mm

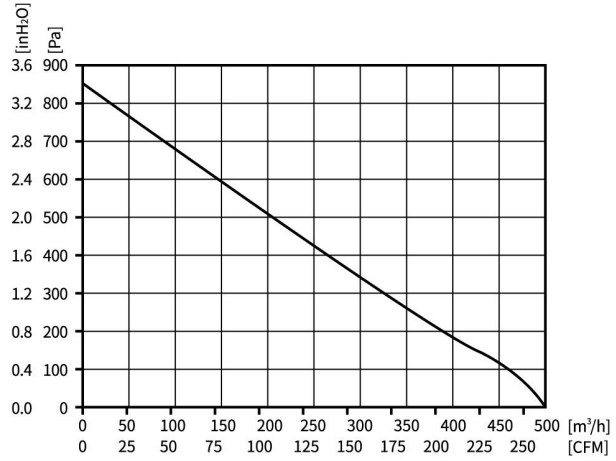

Forward Curved Centrifugal Fans

| | | | | | | |
|---|-------------------------------|-------------------------|-----------------------|--|-----------------|-------------------|
| Motor Type DC BRUSHLESS EXTERNAL ROTOR MOTOR | Speed Control 0-10VVDC/PWM | Protection Type IP55 | Insulation Class B | Operating Temperature -25°C ~ +60°C | Weight 1.0KG | Wiring Mode D1 |
|---|-------------------------------|-------------------------|-----------------------|--|-----------------|-------------------|

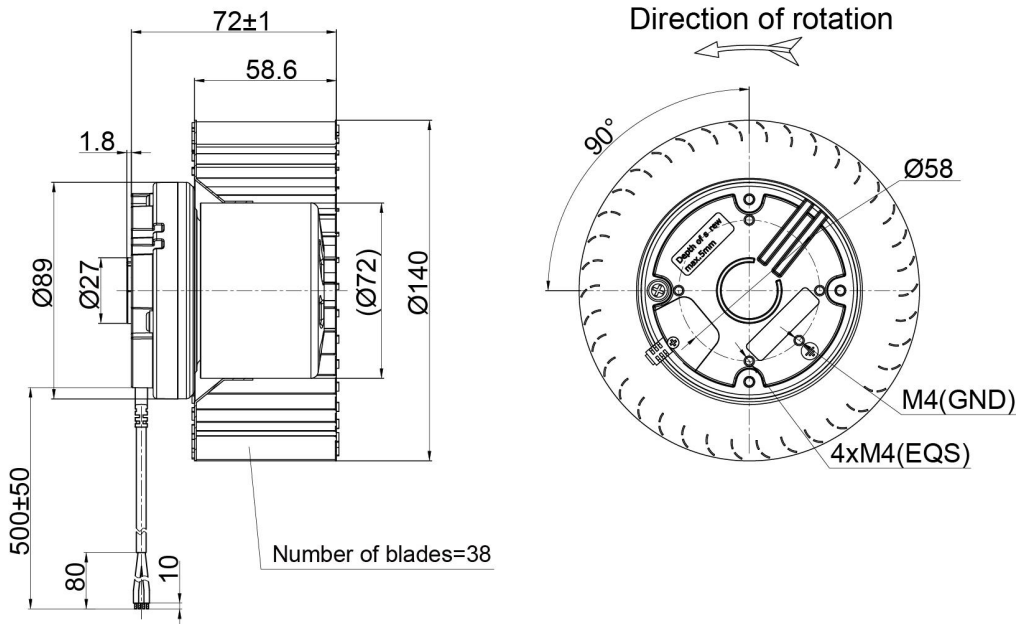

| Model | Motor | Bearing System | Rated Voltage | Operating Voltage | Rated Current | Rated Power | Rated Speed | Air Flow | Air Pressure | Sound Level |
|----------------|--------|----------------|---------------|-------------------|---------------|-------------|-------------|----------|--------------|-------------|
| Part No. | Type | B/S | VDC | VDC | A | W | RPM | M³/H | Pa | dB(A) |
| PF3N140B24-RP0 | BE72DC | BALL | 24 | 16~28 | 2.2 | 52.8 | 1600 | 500 | 850 | 64 |
| PF3N140B48-RP0 | BE72DC | BALL | 48 | 36~57 | 1.1 | 52.8 | 1600 | 500 | 850 | 64 |

DC Centrifugal Fan Forward Curved Ø140x72mm

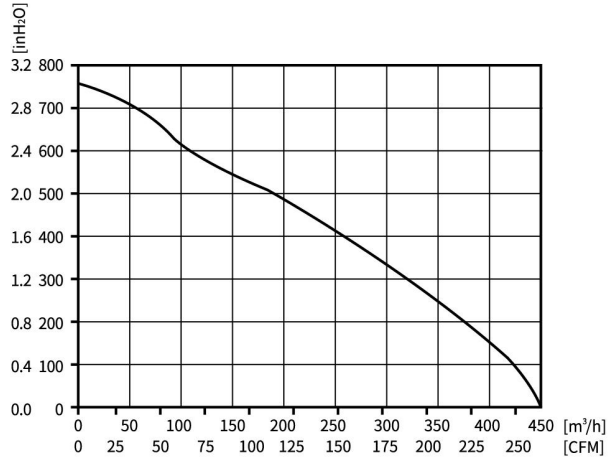

| | | | | | | |
|---|-------------------------------|-------------------------|-----------------------|--|-----------------|-------------------|
| Motor Type DC BRUSHLESS EXTERNAL ROTOR MOTOR | Speed Control 0-10VVDC/PWM | Protection Type IP55 | Insulation Class B | Operating Temperature -25°C ~ +60°C | Weight 1.2KG | Wiring Mode D1 |
|---|-------------------------------|-------------------------|-----------------------|--|-----------------|-------------------|

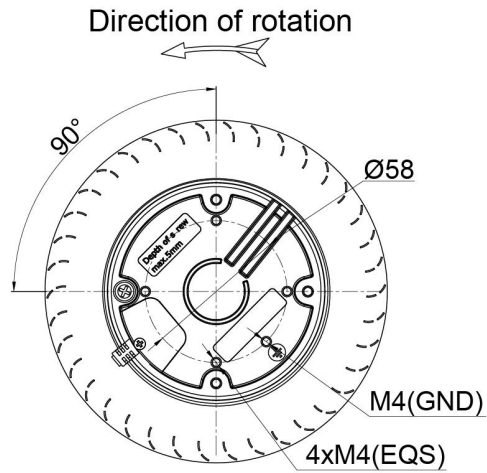
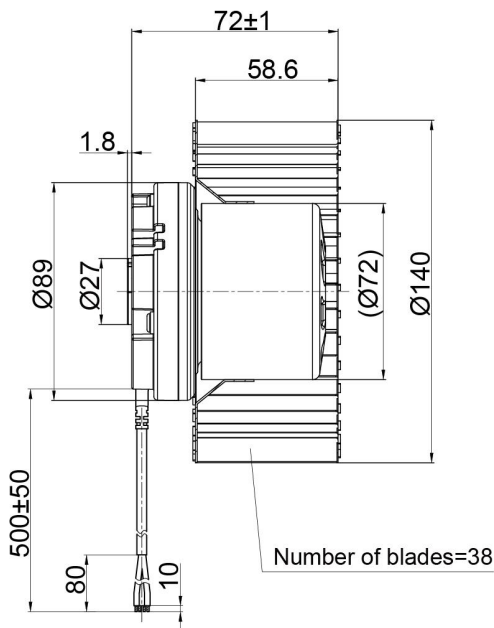

Forward Curved Centrifugal Fans

| Model | Motor | Bearing System | Rated Voltage | Operating Voltage | Rated Current | Rated Power | Rated Speed | Air Flow | Air Pressure | Sound Level |
|----------------|--------|----------------|---------------|-------------------|---------------|-------------|-------------|-------------------|--------------|-------------|
| Part No. | Type | B/S | VDC | VDC | A | W | RPM | M ³ /H | Pa | dB(A) |
| PF3N140B24-RZ0 | BE72DC | BALL | 24 | 16~28 | 2.4 | 57.6 | 1600 | 450 | 760 | 64 |
| PF3N140B48-RZ0 | BE72DC | BALL | 48 | 36~57 | 1.2 | 57.6 | 1600 | 450 | 760 | 64 |

DC Centrifugal Fan Forward Curved Ø160x108mm

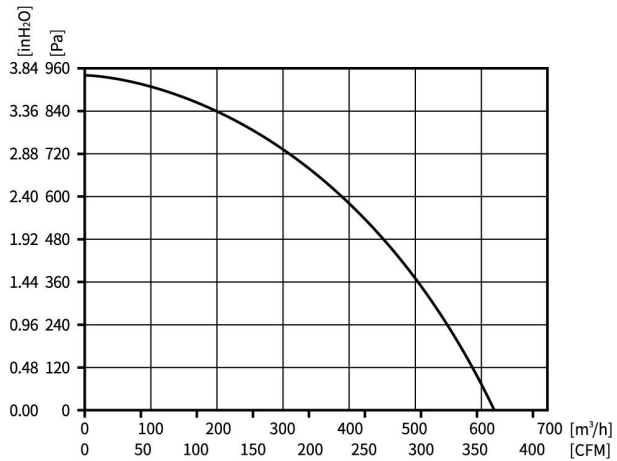

Forward Curved Centrifugal Fans

| | | | | | | |
|---|-------------------------------|-------------------------|-----------------------|--|-----------------|-------------------|
| Motor Type DC BRUSHLESS EXTERNAL ROTOR MOTOR | Speed Control 0-10VVDC/PWM | Protection Type IP55 | Insulation Class B | Operating Temperature -25°C ~ +60°C | Weight 1.3KG | Wiring Mode D1 |
|---|-------------------------------|-------------------------|-----------------------|--|-----------------|-------------------|

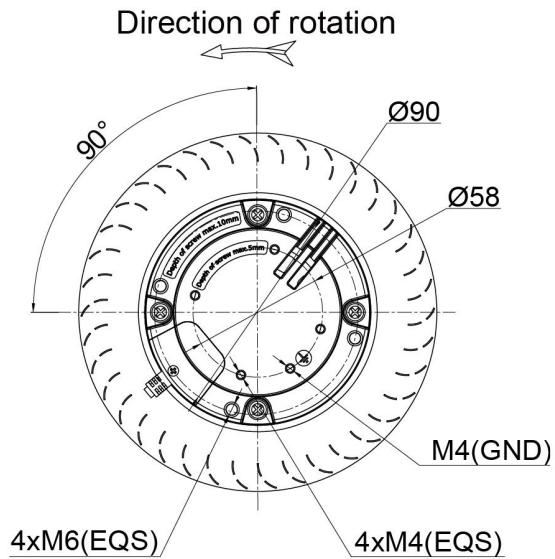
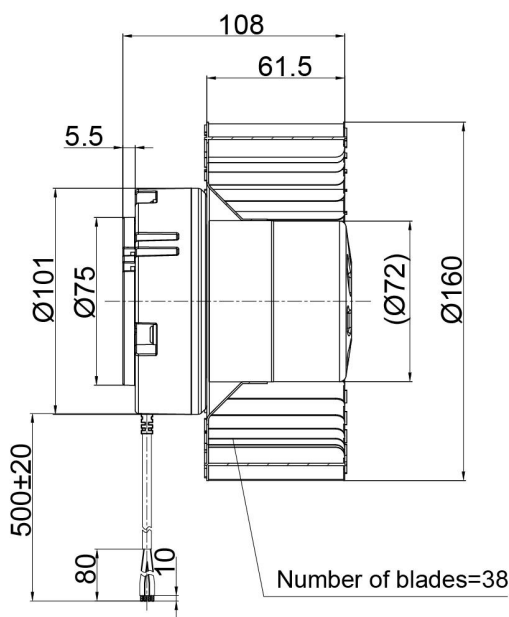

| Model | Motor | Bearing System | Rated Voltage | Operating Voltage | Rated Current | Rated Power | Rated Speed | Air Flow | Air Pressure | Sound Level |
|----------------|--------|----------------|---------------|-------------------|---------------|-------------|-------------|-------------------|--------------|-------------|
| Part No. | Type | B/S | VDC | VDC | A | W | RPM | M ³ /H | Pa | dB(A) |
| PF3N160B24-TP0 | BE72DC | BALL | 24 | 16~28 | 6.8 | 163.2 | 2000 | 620 | 940 | 70 |
| PF3N160B48-TP0 | BE72DC | BALL | 48 | 36~57 | 3.4 | 163.2 | 2000 | 620 | 940 | 70 |

DC Centrifugal Fan Forward Curved $\varnothing 160 \times 108 \text{mm}$

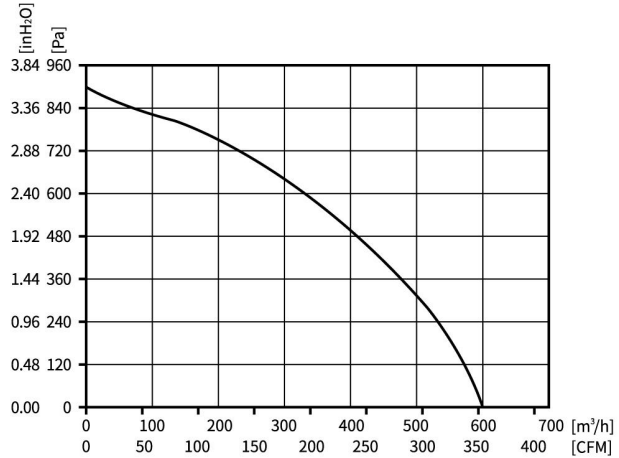

| | | | | | | |
|---|-------------------------------|-------------------------|-----------------------|--|-----------------|-------------------|
| Motor Type DC BRUSHLESS EXTERNAL ROTOR MOTOR | Speed Control 0-10VVDC/PWM | Protection Type IP55 | Insulation Class B | Operating Temperature -25°C ~ +60°C | Weight 1.5KG | Wiring Mode D1 |
|---|-------------------------------|-------------------------|-----------------------|--|-----------------|-------------------|

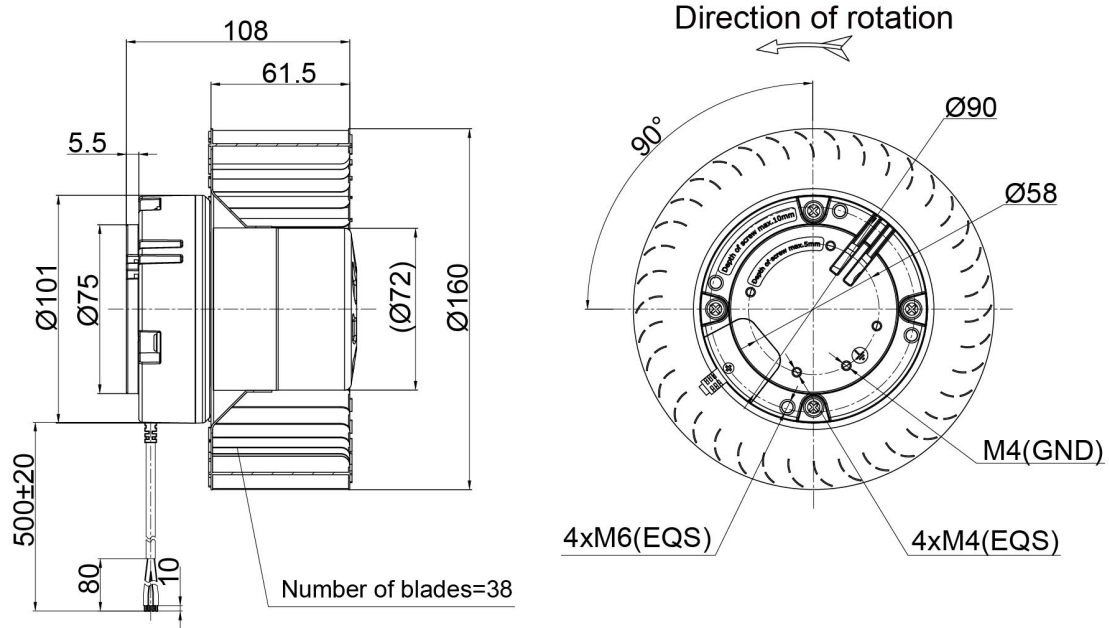

| Model | Motor | Bearing System | Rated Voltage | Operating Voltage | Rated Current | Rated Power | Rated Speed | Air Flow | Air Pressure | Sound Level |
|----------------|--------|----------------|---------------|-------------------|---------------|-------------|-------------|-------------------|--------------|-------------|
| Part No. | Type | B/S | VDC | VDC | A | W | RPM | M ³ /H | Pa | dB(A) |
| PF3N160B24-TZ0 | BE72DC | BALL | 24 | 16~28 | 6.8 | 163.2 | 2000 | 600 | 900 | 69 |
| PF3N160B48-TZ0 | BE72DC | BALL | 48 | 36~57 | 3.4 | 163.2 | 2000 | 600 | 900 | 69 |

Forward Curved Centrifugal Fans