



PBM Motor and Fan (Suzhou) Co., Ltd

No.69 Weixin Road,Suzhou Industrial Park,Suzhou,City,Jiangsu Province,P.R.China

Tel: +86 512 6858 1674

Fax: +86 512 6858 1574

Sales Department: sales@pbmmf.com

After Sales Department: daniel@pbmmf.com



PBM MOTOR AND FAN(SUZHOU) CO.,LTD



Axial Fan



Backward & Forward Curved Centrifugal Fan



Blower

CONTENTS

EC-AC Series

■ Axial Fans	02-26
■ Backward Curved Centrifugal Fans	27-63
■ Forward Curved Centrifugal Fans	64-77
■ Single Inlet Blowers	78-90
■ Dual Inlet Blowers	91-95

EC-DC Series

■ Axial Fans	97-100
■ Backward Curved Centrifugal Fans	101-112
■ Forward Curved Centrifugal Fans	113-118
■ Single Inlet Blowers	119-124

Technology

■ Accessories	125-128
■ Wiring Diagrams	129-133
■ Technical Support	134-140

About us



Company Profile

PBM is a China mainland EC(Electronically Commutated) brushless motor manufacturing and technology consulting company offering an extensive range of EC motors, fans and intelligent ventilation solutions for air-moving precisely and constantly with maintenance-free throughout the life cycle of products in last decades.

R&D and Technical Support

Our R&D and technical support team commits to combine interactively external motor technology, integrated electronic control circuit and aerodynamic design of fan impeller that satisfied customers' requirements in different applications by innovative fan solutions, with leading experiment equipment, meters, tools in laboratory for motor reliability and fan air performance testing. We are pursuing extremely compact brushless permanent magnet synchronous external rotor motor to drive various impeller types and sizes: diagonal axial, backward and forward curved centrifugal, radial, single inlet and dual inlet blower, tangential, cross flow, from minimum 30mm to 560mm diameter with airflow maximum to 12,000CMH cubic meter per hour (equal to approx. 7,000CFM cubic feet per minutes). Maximum motor input power goes to 1.5KW (equal to 2 horsepower) at rotor diameter 138mm.

Production and Quality Control

Economical efficient supply chain guarantees our manufacturing team and quality management team could constantly offer stable products within promised competitive lead time. We continuously invest on semi-automatic or automatic motor and fan assembly lines, equipment, fixtures and jigs to enhance our cost advantage production capability. Not only adopted in ISO9001 Quality Management System ISO 14000 Environment Management System and ISO 45001 Occupational Health and Safety Management system, but also adopted in a long-term Eco-friendly and People-oriented sustainable development of company for last 10 years.

Marketing and Sales

Hundreds of worldwide ventilation, refrigeration, air purification, home appliance, companies from more than fifty countries are adopting PBM EC green-tech motorized fans in their product units and systems that were protecting natural environment and indoor environment of our home to be sustainable green and clean. Our agent and distributor network and online service team covered popular EC fan markets to ensure prompt technical support.

Vision and Mission

Focus on EC fan only and protect our world with intelligent energy efficient motor and fan solutions are our goal in an attempt to make tomorrow a greener & healthier world.

EC Fans Technical Features Overview

Intelligent EC Fan Technology Introduction

PBM series EC (Electronically Commuted) Fans combine interactively external motor technology, integrated electronic control circuit and aerodynamic design of fan impeller that satisfied customers' requirements in different applications and industries by innovative air-moving solutions.

We are pursuing Ultra-low Energy Consumption fans by extremely compact brushless permanent magnet synchronous external rotor motor to drive various of aerodynamic optimized impeller and scroll-housing types and sizes: diagonal axial, backward and forward curved centrifugal, radial, single inlet and dual inlet blower, tangential, cross flow.

Impeller Sizes: From minimum 30mm to 500mm diameter;

Sound Level: From 31dB(A) to maximum 93dB(A) according to different rotation speed;

Air Flow: Maximum to 8,700CMH, Cubic Meter per Hour, equal to approx. 5,120CFM, Cubic Feet per Minute;

Air Pressure: Maxim 1,600Pa, equal to 163.5mm H₂O and to 6.42 inH₂O;

Power: Maximum motor input power goes to 3.1KW (equal to 4.2hp, horsepower) at motor diameter 138mm.



Eco-friendly EC Motor Technology Introduction

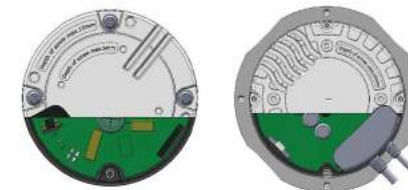

EC=Electronically Commutated
EC brushless permanent magnet synchronous external rotor motor compact with integrated electronic controller built-in for fan applications.

- Variable speed setting by 0~10V DC or PWM signal input;
- AC(1- or 3-phase) public power grid supply connects to motor directly without transformer, voltage stabilizer with silicon rectifier; no surge current by soft-start and PFC circuit integrated;
- Motor efficiency goes up to Maximum 91% for energy-saving and emissions-reducing;
- Low noise by sine wave 3-core brushless commutation motor design with oblique magnetization;
- Always rotation in the correct direction;
- Operating at either 50Hz and 60Hz; 184~270 VAC 1-;
- Operating at a wide voltage range; 304~456 VAC 3-;
- Operating temperature rise is much cooler in electric motors for longer lifespan.

Part Number System

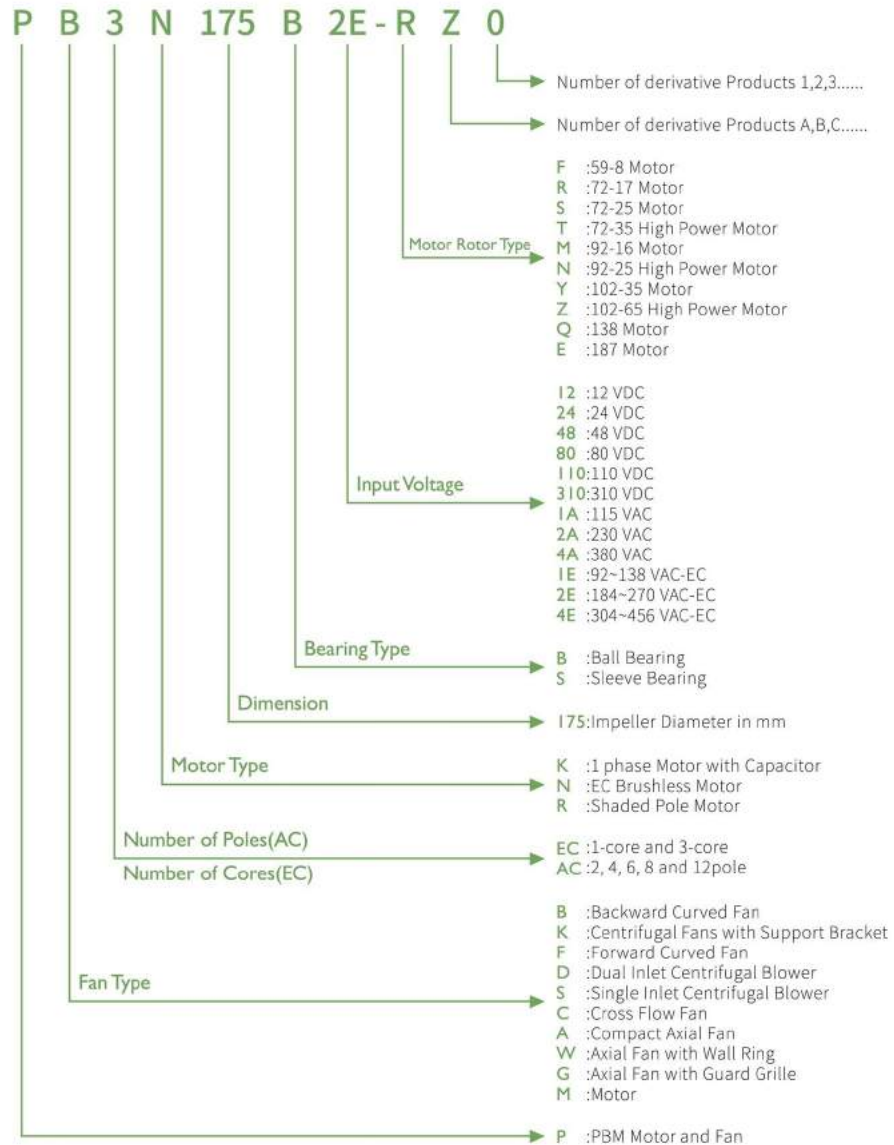

EC-AC Series



EC Axial Fan Ø200x72.5mm

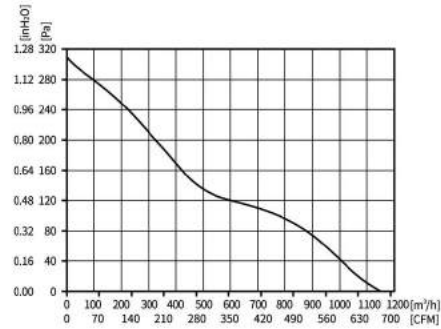

Motor Type EC BRUSHLESS EXTERNAL ROTOR MOTOR	Speed Control 0-10VDC/PWM	Protection Type IP55	Insulation Class B	Operating Temperature -25°C~+60°C	Weight 1.2KG	Wiring Mode E1
---	------------------------------	-------------------------	-----------------------	--------------------------------------	-----------------	-------------------

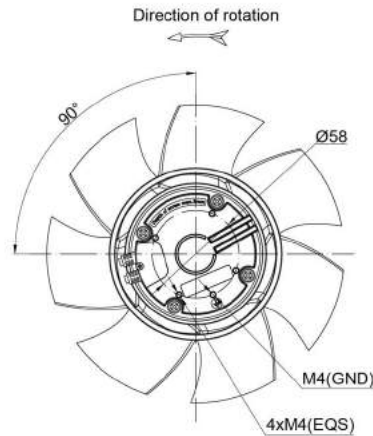
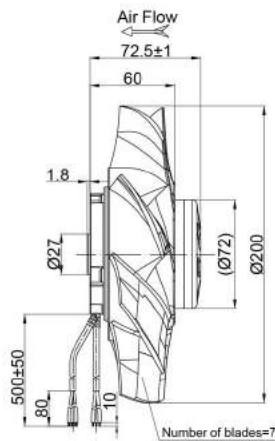

Model	Motor	Bearing System	Rated Voltage	Frequency	Rated Current	Rated Power	Rated Speed	Air Flow	Air Pressure	Sound Level
Part No.	Type	B/S	VAC	Hz	A	W	RPM	M ³ /H	Pa	dB(A)
PA3N200B2E-RN0	BE72EC	BALL	230	50/60	0.45	58	3000	1150	310	62

EC Axial Fan Ø200x80mm

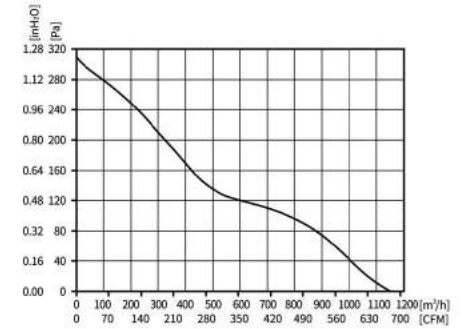

Motor Type EC BRUSHLESS EXTERNAL ROTOR MOTOR	Speed Control 0-10VDC/PWM	Protection Type IP55	Insulation Class B	Operating Temperature -25°C~+60°C	Weight 1.86KG	Wiring Mode E1
---	------------------------------	-------------------------	-----------------------	--------------------------------------	------------------	-------------------

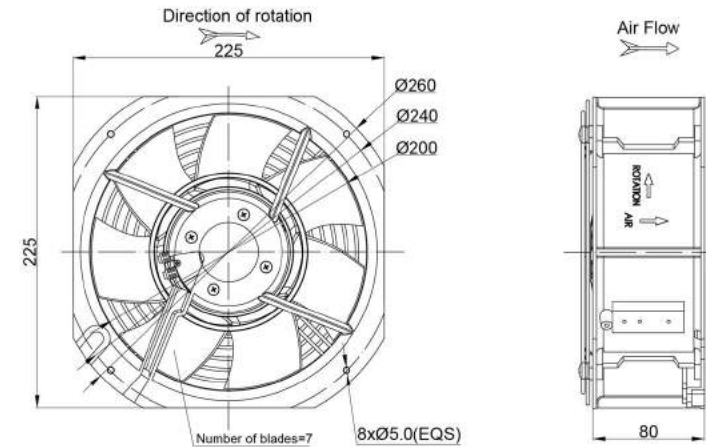

Model	Motor	Bearing System	Rated Voltage	Frequency	Rated Current	Rated Power	Rated Speed	Air Flow	Air Pressure	Sound Level
Part No.	Type	B/S	VAC	Hz	A	W	RPM	M ³ /H	Pa	dB(A)
PA3N200B2E-RZ0	BE72EC	BALL	230	50/60	0.45	58	3000	1150	310	62

EC Axial Fan $\varnothing 200 \times 80.5 \text{mm}$

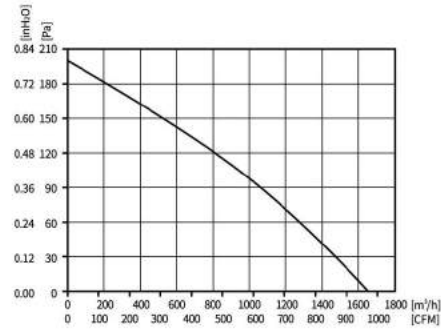

Motor Type EC BRUSHLESS EXTERNAL ROTOR MOTOR	Speed Control 0-10VDC/PWM	Protection Type IP55	Insulation Class B	Operating Temperature -25°C ~ +60°C	Weight 1.2KG	Wiring Mode E1
---	------------------------------	-------------------------	-----------------------	--	-----------------	-------------------

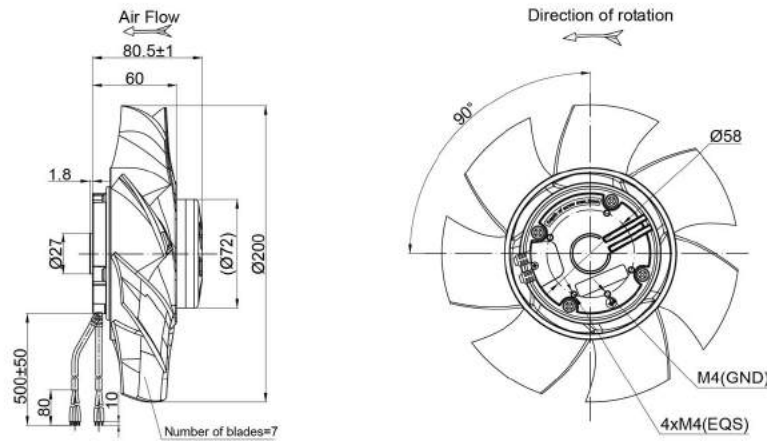

Model	Motor	Bearing System	Rated Voltage	Frequency	Rated Current	Rated Power	Rated Speed	Air Flow	Air Pressure	Sound Level
Part No.	Type	B/S	VAC	Hz	A	W	RPM	M ³ /H	Pa	dB(A)
PA3N200B2E-SN0	BE72EC	BALL	230	50/60	0.85	115	4100	1650	200	66

EC Axial Fan $\varnothing 200 \times 80 \text{mm}$

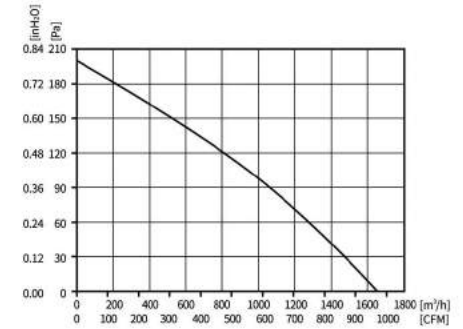

Motor Type EC BRUSHLESS EXTERNAL ROTOR MOTOR	Speed Control 0-10VDC/PWM	Protection Type IP55	Insulation Class B	Operating Temperature -25°C ~ +60°C	Weight 1.86KG	Wiring Mode E1
---	------------------------------	-------------------------	-----------------------	--	------------------	-------------------

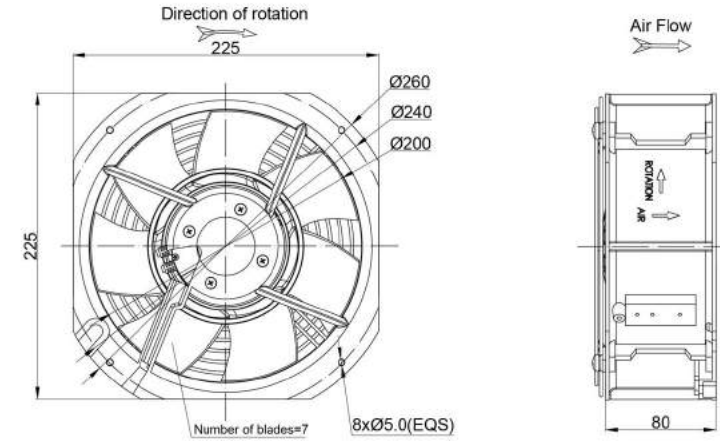

Model	Motor	Bearing System	Rated Voltage	Frequency	Rated Current	Rated Power	Rated Speed	Air Flow	Air Pressure	Sound Level
Part No.	Type	B/S	VAC	Hz	A	W	RPM	M ³ /H	Pa	dB(A)
PA3N200B2E-SZ0	BE72EC	BALL	230	50/60	0.85	115	4100	1650	200	66

EC Axial Fan Ø250x72.5mm

EC Axial Fan Ø250x80mm

Axial Fans

Axial Fans

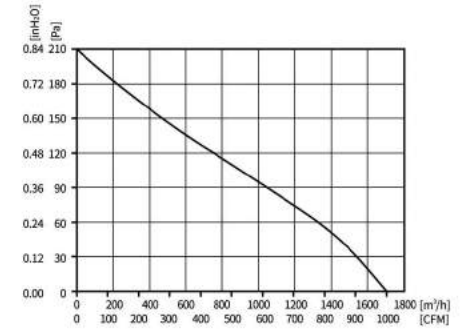
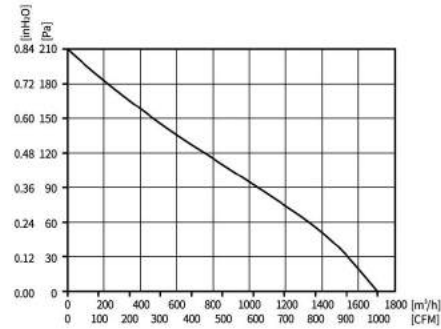

Motor Type EC BRUSHLESS EXTERNAL ROTOR MOTOR	Speed Control 0-10VDC/PWM	Protection Type IP55	Insulation Class B	Operating Temperature -25°C ~ +60°C	Weight 1.4KG	Wiring Mode E1
---	------------------------------	-------------------------	-----------------------	--	-----------------	-------------------

Motor Type EC BRUSHLESS EXTERNAL ROTOR MOTOR	Speed Control 0-10VDC/PWM	Protection Type IP55	Insulation Class B	Operating Temperature -25°C ~ +60°C	Weight 2.2KG	Wiring Mode E1
---	------------------------------	-------------------------	-----------------------	--	-----------------	-------------------

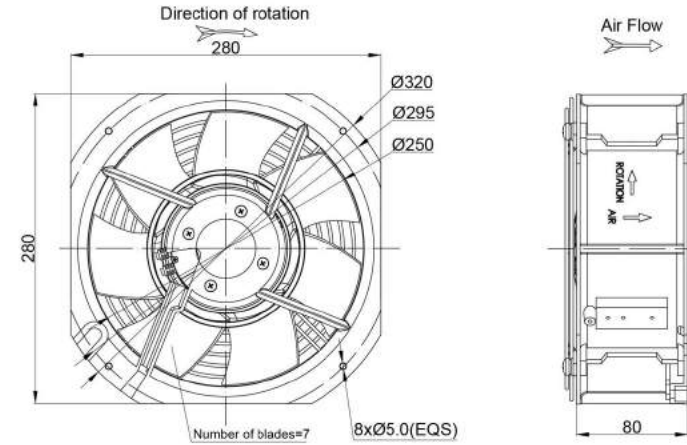
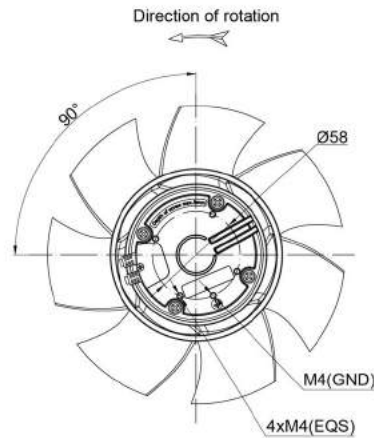
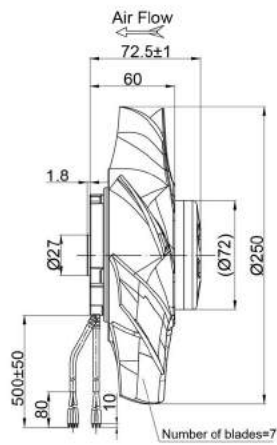

Model	Motor	Bearing System	Rated Voltage	Frequency	Rated Current	Rated Power	Rated Speed	Air Flow	Air Pressure	Sound Level
Part No.	Type	B/S	VAC	Hz	A	W	RPM	M³/H	Pa	dB(A)
PA3N250B2E-RN0	BE72EC	BALL	230	50/60	0.65	85	2600	1700	210	61

Model	Motor	Bearing System	Rated Voltage	Frequency	Rated Current	Rated Power	Rated Speed	Air Flow	Air Pressure	Sound Level
Part No.	Type	B/S	VAC	Hz	A	W	RPM	M³/H	Pa	dB(A)
PA3N250B2E-RZ0	BE72EC	BALL	230	50/60	0.65	85	2600	1700	210	61

EC Axial Fan Ø250x80.5mm

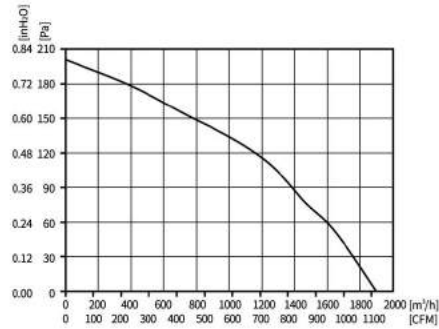

Motor Type EC BRUSHLESS EXTERNAL ROTOR MOTOR	Speed Control 0-10VDC/PWM	Protection Type IP55	Insulation Class B	Operating Temperature -25°C~+60°C	Weight 1.4KG	Wiring Mode E1
---	------------------------------	-------------------------	-----------------------	--------------------------------------	-----------------	-------------------

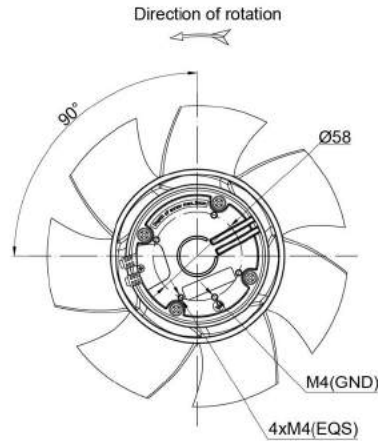
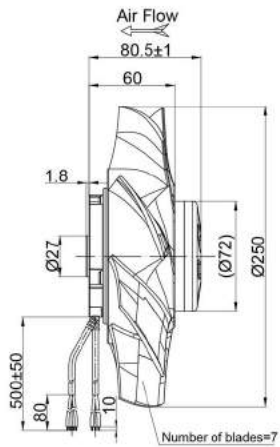

Model	Motor	Bearing System	Rated Voltage	Frequency	Rated Current	Rated Power	Rated Speed	Air Flow	Air Pressure	Sound Level
Part No.	Type	B/S	VAC	Hz	A	W	RPM	M³/H	Pa	dB(A)
PA3N250B2E-SN0	BE72EC	BALL	230	50/60	0.9	120	3000	1900	200	63

EC Axial Fan Ø250x80mm

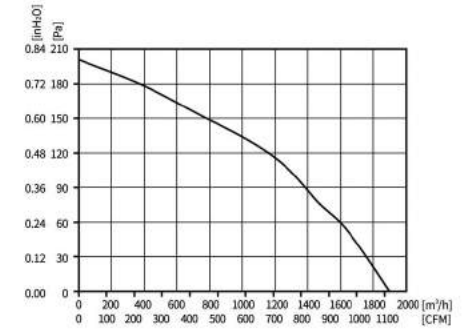

Motor Type EC BRUSHLESS EXTERNAL ROTOR MOTOR	Speed Control 0-10VDC/PWM	Protection Type IP55	Insulation Class B	Operating Temperature -25°C~+60°C	Weight 2.2KG	Wiring Mode E1
---	------------------------------	-------------------------	-----------------------	--------------------------------------	-----------------	-------------------

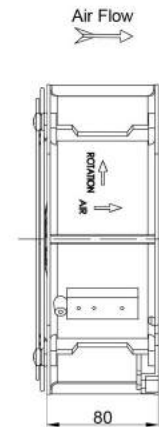
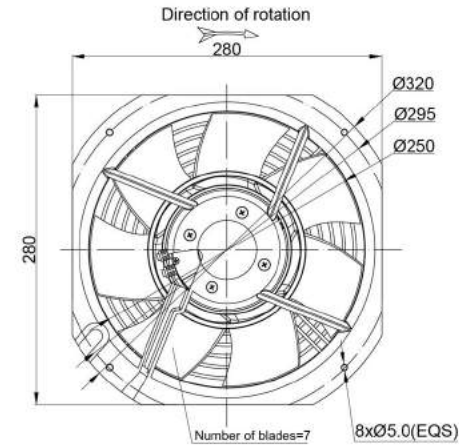

Model	Motor	Bearing System	Rated Voltage	Frequency	Rated Current	Rated Power	Rated Speed	Air Flow	Air Pressure	Sound Level
Part No.	Type	B/S	VAC	Hz	A	W	RPM	M³/H	Pa	dB(A)
PA3N250B2E-SZ0	BE72EC	BALL	230	50/60	0.9	120	3000	1900	200	63

EC Axial Fan $\varnothing 300 \times 102 \text{mm}$

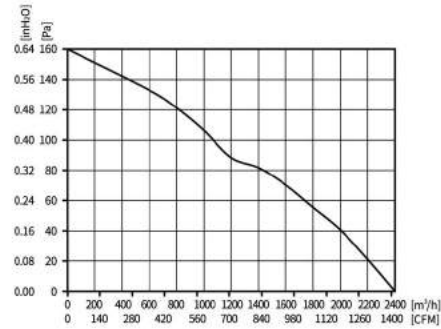

Motor Type	Speed Control	Protection Type	Insulation Class	Operating Temperature	Weight	Wiring Mode
EC BRUSHLESS EXTERNAL ROTOR MOTOR	0-10VDC/PWM	IP55	B	-25°C ~ +60°C	2.1KG	E1

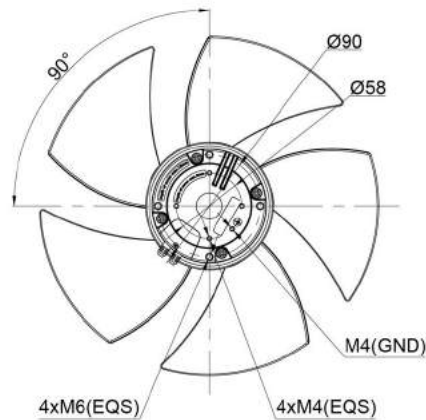
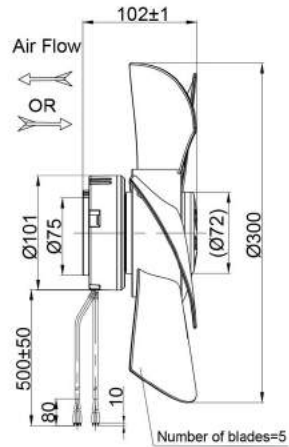

Model	Motor	Bearing System	Rated Voltage	Frequency	Rated Current	Rated Power	Rated Speed	Air Flow	Air Pressure	Sound Level
Part No.	Type	B/S	VAC	Hz	A	W	RPM	M³/H	Pa	dB(A)
PG3N300B2E-TN0	BE72EC	BALL	230	50/60	1.1	150	1920	2400	160	66

EC Axial Fan $\varnothing 360 \times 106.5 \text{mm}$

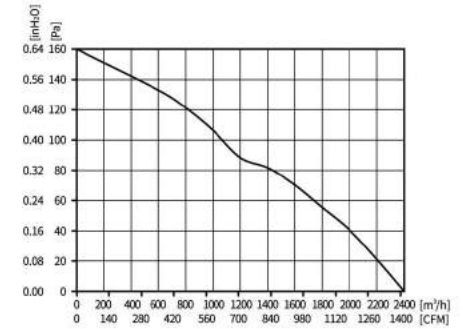

Motor Type	Speed Control	Protection Type	Insulation Class	Operating Temperature	Weight	Wiring Mode
EC BRUSHLESS EXTERNAL ROTOR MOTOR	0-10VDC/PWM	IP55	B	-25°C ~ +60°C	3.2KG	E1

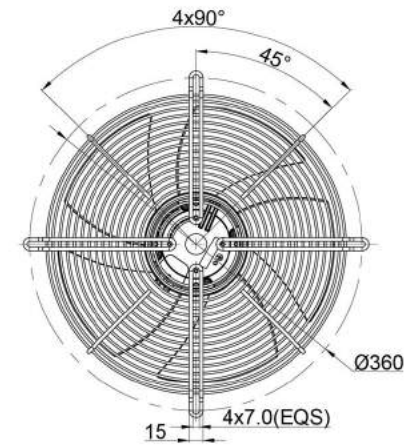
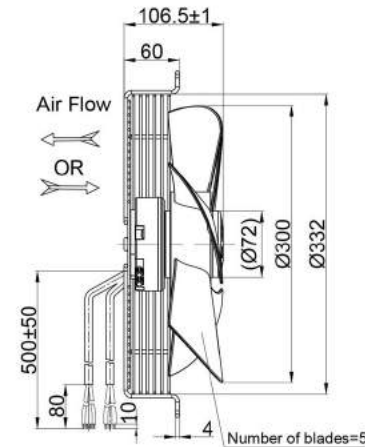

Model	Motor	Bearing System	Rated Voltage	Frequency	Rated Current	Rated Power	Rated Speed	Air Flow	Air Pressure	Sound Level
Part No.	Type	B/S	VAC	Hz	A	W	RPM	M³/H	Pa	dB(A)
PG3N300B2E-TZ0	BE72EC	BALL	230	50/60	1.1	150	1920	2400	160	66

Axial Fans

Axial Fans

EC Axial Fan $\varnothing 368 \times 90 \text{mm}$

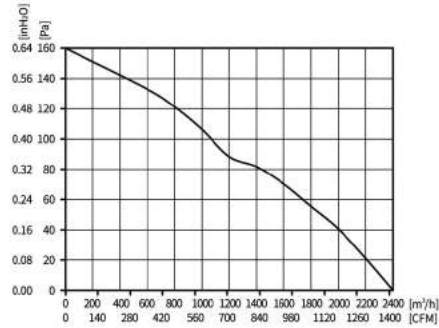

Motor Type	Speed Control	Protection Type	Insulation Class	Operating Temperature	Weight	Wiring Mode
EC BRUSHLESS EXTERNAL ROTOR MOTOR	0-10VDC/PWM	IP55	B	-25°C ~ +60°C	3.4KG	E1

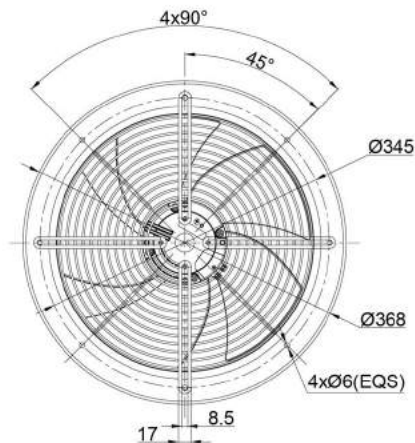
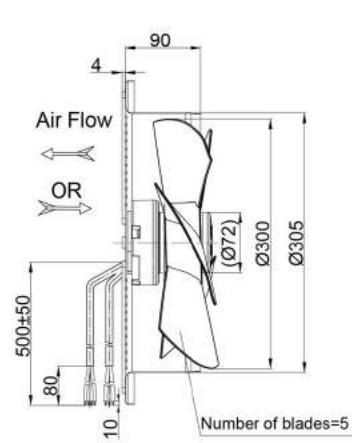

Model	Motor	Bearing System	Rated Voltage	Frequency	Rated Current	Rated Power	Rated Speed	Air Flow	Air Pressure	Sound Level
Part No.	Type	B/S	VAC	Hz	A	W	RPM	M³/H	Pa	dB(A)
PW3N300B2E-TZ0	BE72EC	BALL	230	50/60	1.1	150	1920	2400	160	66

EC Axial Fan $\varnothing 300 \times 96.5 \text{mm}$

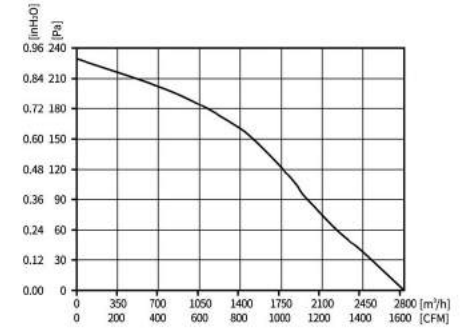

Motor Type	Speed Control	Protection Type	Insulation Class	Operating Temperature	Weight	Wiring Mode
EC BRUSHLESS EXTERNAL ROTOR MOTOR	0-10VDC/PWM	IP55	B	-25°C ~ +60°C	2.8KG	E2

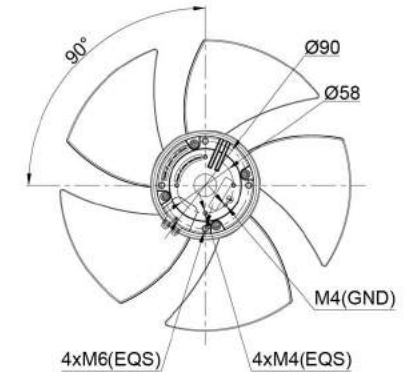
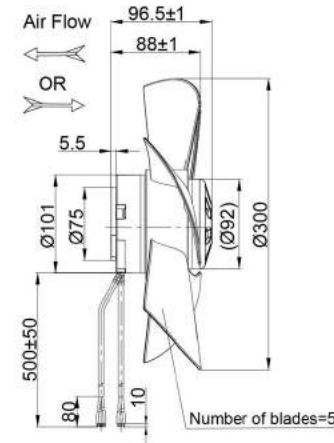

Model	Motor	Bearing System	Rated Voltage	Frequency	Rated Current	Rated Power	Rated Speed	Air Flow	Air Pressure	Sound Level
Part No.	Type	B/S	VAC	Hz	A	W	RPM	M³/H	Pa	dB(A)
PG3N300B2E-MN0	BE92EC	BALL	230	50/60	1.5	220	2200	2800	230	68

Axial Fans

Axial Fans

EC Axial Fan Ø360x100.5mm

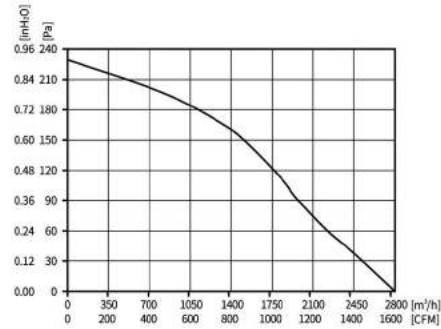

Motor Type EC BRUSHLESS EXTERNAL ROTOR MOTOR	Speed Control 0-10VDC/PWM	Protection Type IP55	Insulation Class B	Operating Temperature -25°C ~ +60°C	Weight 4.0KG	Wiring Mode E2
---	------------------------------	-------------------------	-----------------------	--	-----------------	-------------------

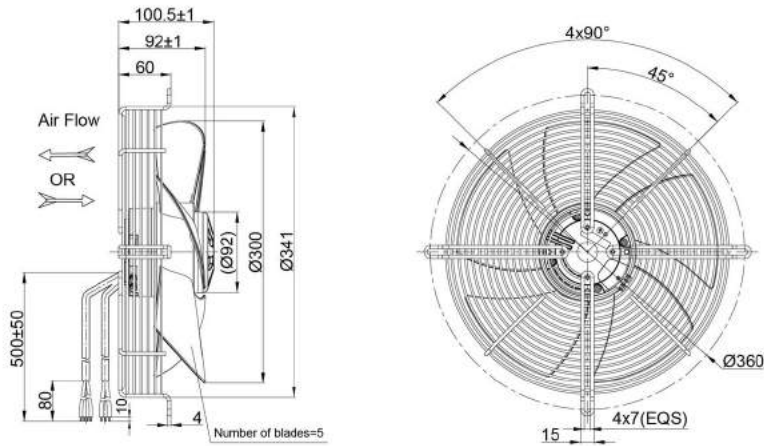

Model	Motor	Bearing System	Rated Voltage	Frequency	Rated Current	Rated Power	Rated Speed	Air Flow	Air Pressure	Sound Level
Part No.	Type	B/S	VAC	Hz	A	W	RPM	M ³ /H	Pa	dB(A)
PG3N300B2E-MZO	BE92EC	BALL	230	50/60	1.5	220	2200	2800	230	68

EC Axial Fan Ø350x177mm

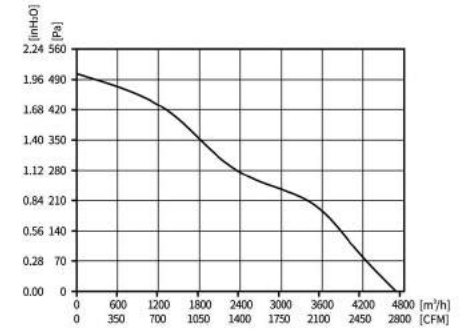

Motor Type EC BRUSHLESS EXTERNAL ROTOR MOTOR	Speed Control 0-10VDC/PWM	Protection Type IP55	Insulation Class F	Operating Temperature -25°C ~ +60°C	Weight 6.1KG	Wiring Mode E3
---	------------------------------	-------------------------	-----------------------	--	-----------------	-------------------

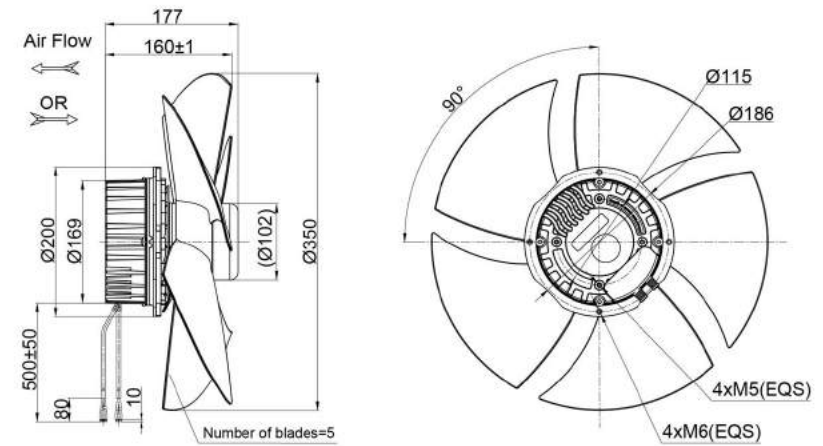

Model	Motor	Bearing System	Rated Voltage	Frequency	Rated Current	Rated Power	Rated Speed	Air Flow	Air Pressure	Sound Level
Part No.	Type	B/S	VAC	Hz	A	W	RPM	M ³ /H	Pa	dB(A)
PG3N350B2E-ZN5	BE102EC	BALL	230	50/60	3.1	700	2500	4700	500	69

EC Axial Fan Ø422x175.5mm

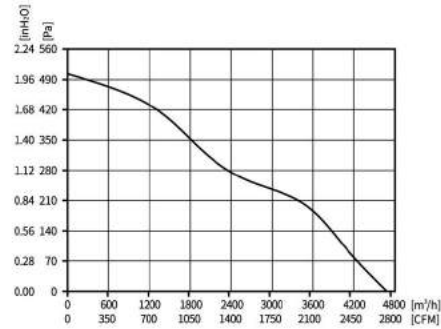

Motor Type EC BRUSHLESS EXTERNAL ROTOR MOTOR	Speed Control 0-10VDC/PWM	Protection Type IP55	Insulation Class F	Operating Temperature -25°C~+60°C	Weight 8.0KG	Wiring Mode E3
---	------------------------------	-------------------------	-----------------------	--------------------------------------	-----------------	-------------------

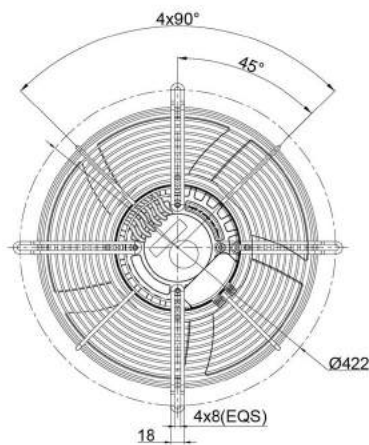
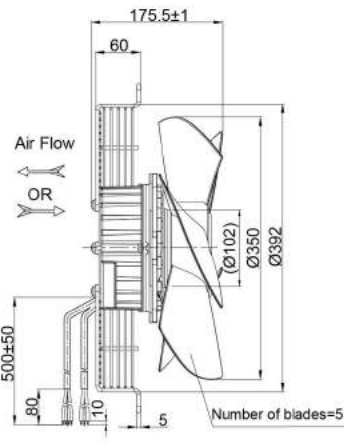

Model	Motor	Bearing System	Rated Voltage	Frequency	Rated Current	Rated Power	Rated Speed	Air Flow	Air Pressure	Sound Level
Part No.	Type	B/S	VAC	Hz	A	W	RPM	M³/H	Pa	dB(A)
PG3N350B2E-ZW5	BE102EC	BALL	230	50/60	3.1	700	2500	4700	500	69

EC Axial Fan Ø350x109mm

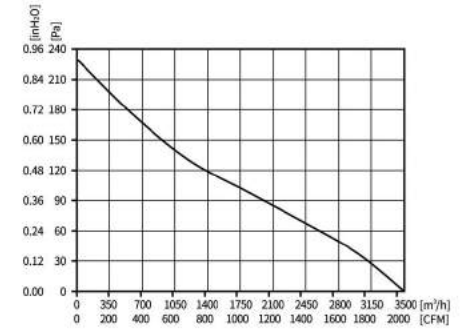

Motor Type EC BRUSHLESS EXTERNAL ROTOR MOTOR	Speed Control 0-10VDC/PWM	Protection Type IP55	Insulation Class B	Operating Temperature -25°C~+60°C	Weight 3.65KG	Wiring Mode E2
---	------------------------------	-------------------------	-----------------------	--------------------------------------	------------------	-------------------

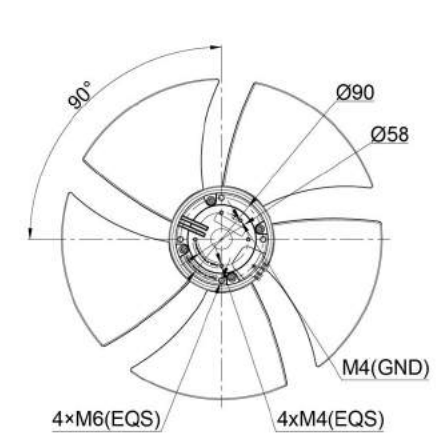
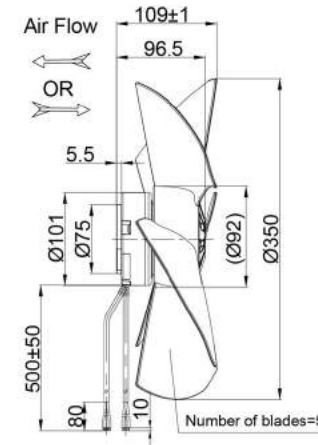

Model	Motor	Bearing System	Rated Voltage	Frequency	Rated Current	Rated Power	Rated Speed	Air Flow	Air Pressure	Sound Level
Part No.	Type	B/S	VAC	Hz	A	W	RPM	M³/H	Pa	dB(A)
PG3N350B2E-MN0	BE92EC	BALL	230	50/60	1.5	200	1580	3500	230	67

EC Axial Fan $\varnothing 422 \times 116.5 \text{mm}$

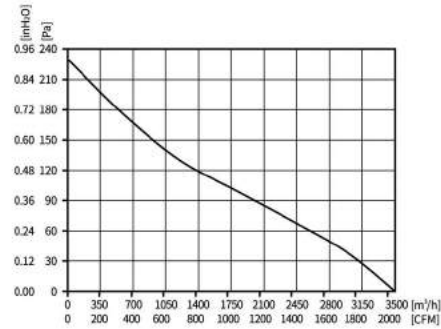

Motor Type EC BRUSHLESS EXTERNAL ROTOR MOTOR	Speed Control 0-10VDC/PWM	Protection Type IP55	Insulation Class B	Operating Temperature -25°C ~ +60°C	Weight 5.5KG	Wiring Mode E2
---	------------------------------	-------------------------	-----------------------	--	-----------------	-------------------

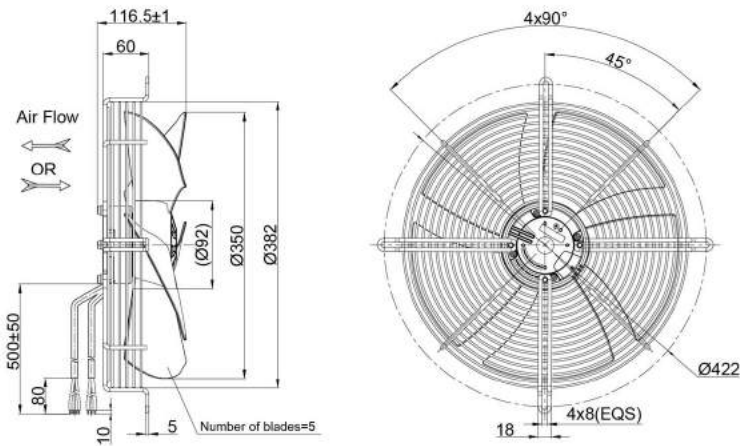

Model	Motor	Bearing System	Rated Voltage	Frequency	Rated Current	Rated Power	Rated Speed	Air Flow	Air Pressure	Sound Level
Part No.	Type	B/S	VAC	Hz	A	W	RPM	M ³ /H	Pa	dB(A)
PG3N350B2E-MZO	BE92EC	BALL	230	50/60	1.5	200	1580	3500	230	67

EC Axial Fan $\varnothing 400 \times 177 \text{mm}$

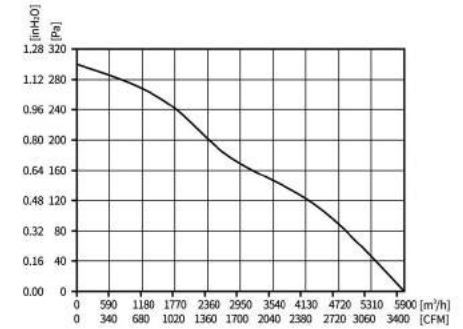

Motor Type EC BRUSHLESS EXTERNAL ROTOR MOTOR	Speed Control 0-10VDC/PWM	Protection Type IP55	Insulation Class F	Operating Temperature -25°C ~ +60°C	Weight 6.4KG	Wiring Mode E3
---	------------------------------	-------------------------	-----------------------	--	-----------------	-------------------

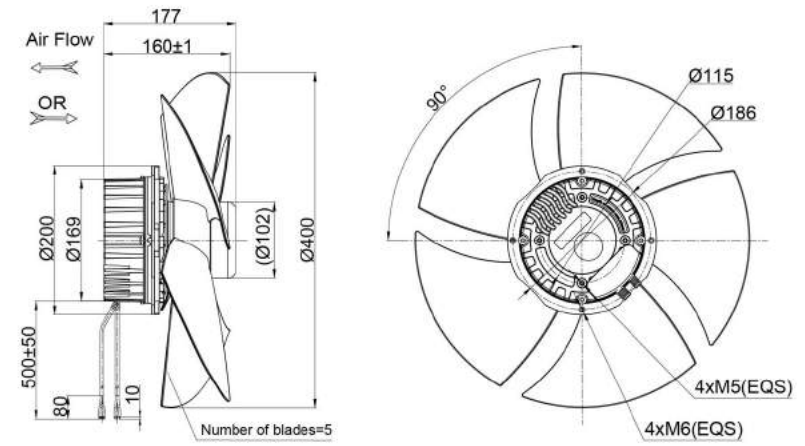

Model	Motor	Bearing System	Rated Voltage	Frequency	Rated Current	Rated Power	Rated Speed	Air Flow	Air Pressure	Sound Level
Part No.	Type	B/S	VAC	Hz	A	W	RPM	M ³ /H	Pa	dB(A)
PG3N400B2E-ZN5	BE102EC	BALL	230	50/60	3.1	700	1800	5900	300	73

Axial Fans

Axial Fans

EC Axial Fan Ø522x181.5mm

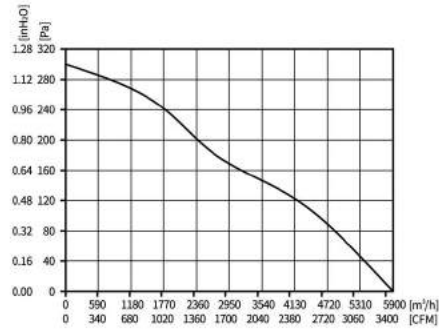

Motor Type EC BRUSHLESS EXTERNAL ROTOR MOTOR	Speed Control 0-10VDC/PWM	Protection Type IP55	Insulation Class F	Operating Temperature -25°C~+60°C	Weight 8.5KG	Wiring Mode E3
---	------------------------------	-------------------------	-----------------------	--------------------------------------	-----------------	-------------------

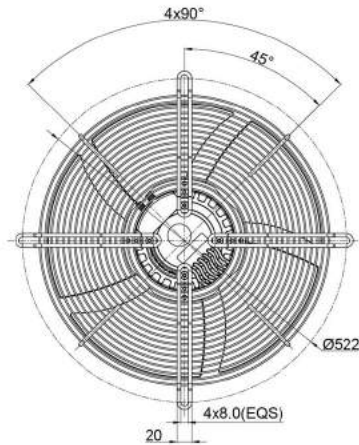
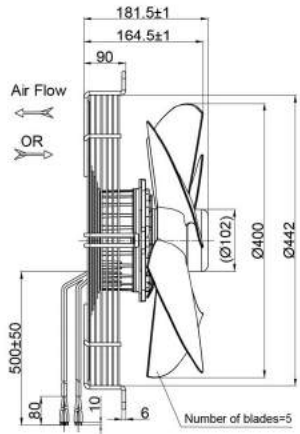

Model	Motor	Bearing System	Rated Voltage	Frequency	Rated Current	Rated Power	Rated Speed	Air Flow	Air Pressure	Sound Level
Part No.	Type	B/S	VAC	Hz	A	W	RPM	M³/H	Pa	dB(A)
PG3N400B2E-ZW5	BE102EC	BALL	230	50/60	3.1	700	1800	5900	300	73

EC Axial Fan Ø400x95mm

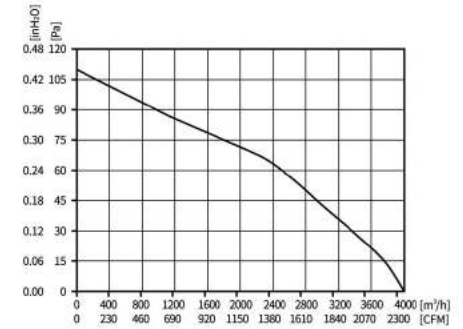

Motor Type EC BRUSHLESS EXTERNAL ROTOR MOTOR	Speed Control 0-10VDC/PWM	Protection Type IP55	Insulation Class B	Operating Temperature -25°C~+60°C	Weight 3.9KG	Wiring Mode E2
---	------------------------------	-------------------------	-----------------------	--------------------------------------	-----------------	-------------------

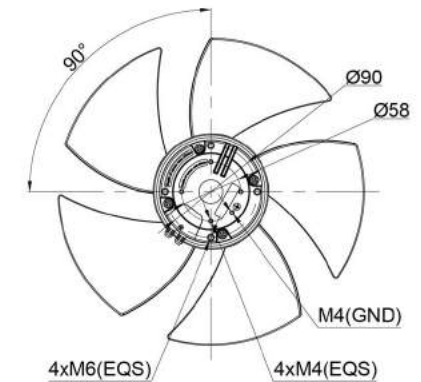
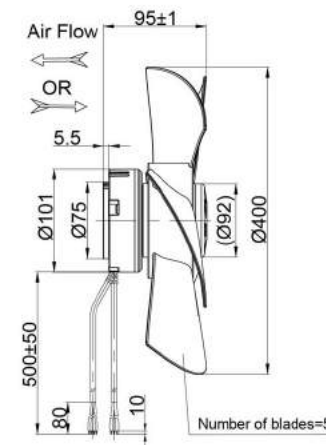

Model	Motor	Bearing System	Rated Voltage	Frequency	Rated Current	Rated Power	Rated Speed	Air Flow	Air Pressure	Sound Level
Part No.	Type	B/S	VAC	Hz	A	W	RPM	M³/H	Pa	dB(A)
PG3N400B2E-MN0	BE92EC	BALL	230	50/60	1.25	170	1200	4000	110	68

EC Axial Fan $\varnothing 470 \times 101.5 \text{mm}$

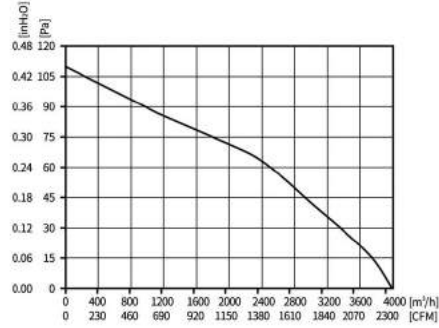

Motor Type EC BRUSHLESS EXTERNAL ROTOR MOTOR	Speed Control 0-10VDC/PWM	Protection Type IP55	Insulation Class B	Operating Temperature -25°C ~ +60°C	Weight 6.5KG	Wiring Mode E2
---	------------------------------	-------------------------	-----------------------	--	-----------------	-------------------

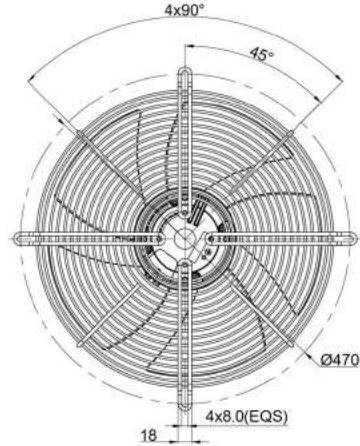
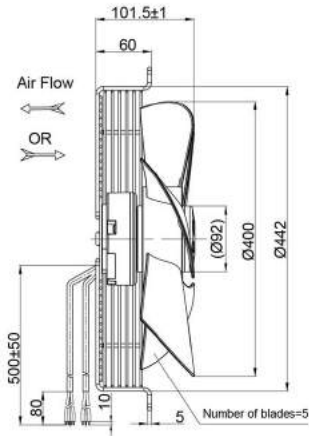

Model	Motor	Bearing System	Rated Voltage	Frequency	Rated Current	Rated Power	Rated Speed	Air Flow	Air Pressure	Sound Level
Part No.	Type	B/S	VAC	Hz	A	W	RPM	M³/H	Pa	dB(A)
PG3N400B2E-MZ0	BE92EC	BALL	230	50/60	1.25	170	1200	4000	110	68

EC Axial Fan $\varnothing 450 \times 177 \text{mm}$

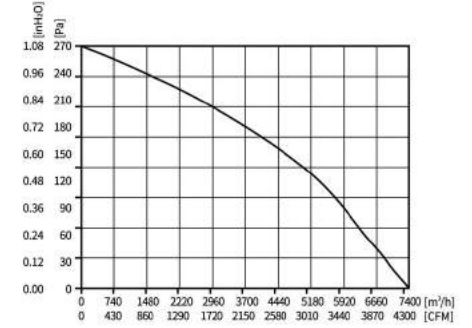

Motor Type EC BRUSHLESS EXTERNAL ROTOR MOTOR	Speed Control 0-10VDC/PWM	Protection Type IP55	Insulation Class F	Operating Temperature -25°C ~ +60°C	Weight 6.5KG	Wiring Mode E3
---	------------------------------	-------------------------	-----------------------	--	-----------------	-------------------

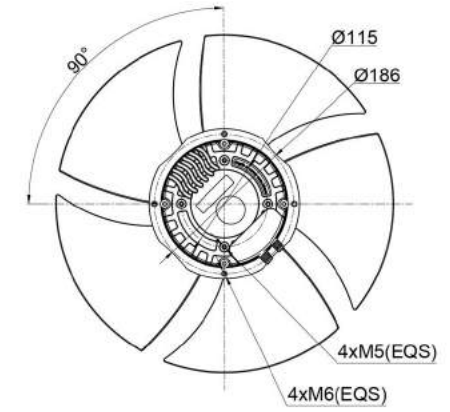
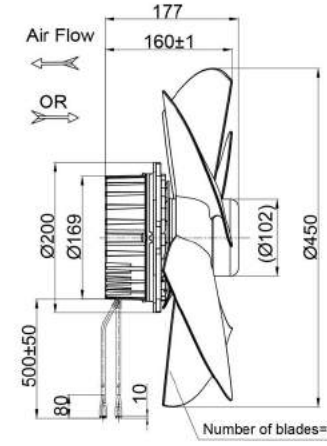

Model	Motor	Bearing System	Rated Voltage	Frequency	Rated Current	Rated Power	Rated Speed	Air Flow	Air Pressure	Sound Level
Part No.	Type	B/S	VAC	Hz	A	W	RPM	M³/H	Pa	dB(A)
PG3N450B2E-ZN5	BE102EC	BALL	230	50/60	1.7	380	1400	7400	270	75

Axial Fans

Axial Fans

EC Axial Fan $\varnothing 522 \times 186 \text{mm}$

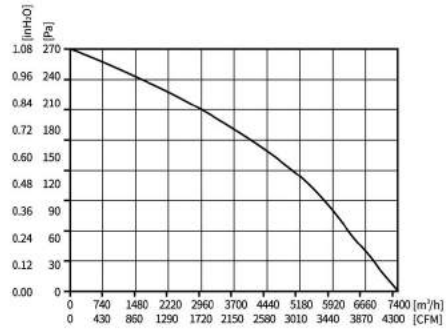

Motor Type EC BRUSHLESS EXTERNAL ROTOR MOTOR	Speed Control 0-10VDC/PWM	Protection Type IP55	Insulation Class F	Operating Temperature -25°C~+60°C	Weight 8.0KG	Wiring Mode E3
---	------------------------------	-------------------------	-----------------------	--------------------------------------	-----------------	-------------------

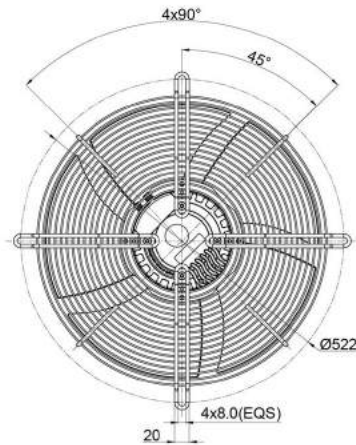
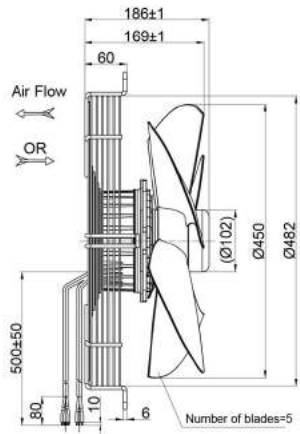

Model	Motor	Bearing System	Rated Voltage	Frequency	Rated Current	Rated Power	Rated Speed	Air Flow	Air Pressure	Sound Level
Part No.	Type	B/S	VAC	Hz	A	W	RPM	M³/H	Pa	dB(A)
PG3N450B2E-ZW5	BE102EC	BALL	230	50/60	1.7	380	1400	7400	270	75

EC Axial Fan $\varnothing 500 \times 177 \text{mm}$

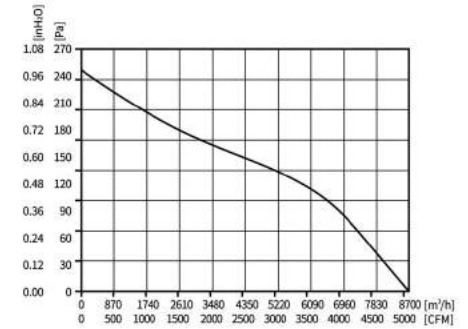

Motor Type EC BRUSHLESS EXTERNAL ROTOR MOTOR	Speed Control 0-10VDC/PWM	Protection Type IP55	Insulation Class F	Operating Temperature -25°C~+60°C	Weight 6.9KG	Wiring Mode E3
---	------------------------------	-------------------------	-----------------------	--------------------------------------	-----------------	-------------------

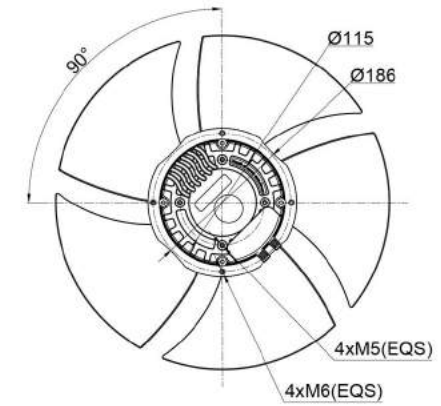
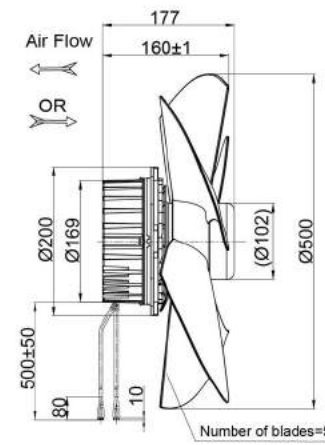

Model	Motor	Bearing System	Rated Voltage	Frequency	Rated Current	Rated Power	Rated Speed	Air Flow	Air Pressure	Sound Level
Part No.	Type	B/S	VAC	Hz	A	W	RPM	M³/H	Pa	dB(A)
PG3N500B2E-ZN5	BE102EC	BALL	230	50/60	3.1	700	1550	8700	250	71

EC Axial Fan $\varnothing 570 \times 186 \text{mm}$

Axial Fans

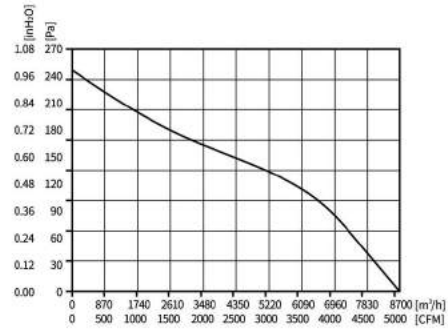

Motor Type EC BRUSHLESS EXTERNAL ROTOR MOTOR	Speed Control 0-10VDC/PWM	Protection Type IP55	Insulation Class F	Operating Temperature -25°C ~ +60°C	Weight 8.1KG	Wiring Mode E3
---	------------------------------	-------------------------	-----------------------	--	-----------------	-------------------

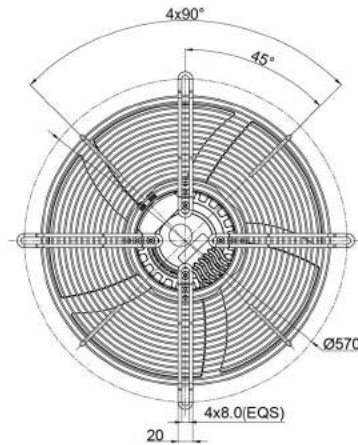
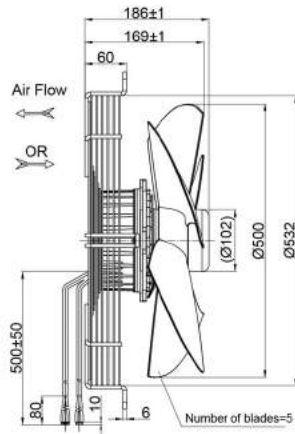

Model	Motor	Bearing System	Rated Voltage	Frequency	Rated Current	Rated Power	Rated Speed	Air Flow	Air Pressure	Sound Level
Part No.	Type	B/S	VAC	Hz	A	W	RPM	M³/H	Pa	dB(A)
PG3N500B2E-ZW5	BE102EC	BALL	230	50/60	3.1	700	1550	8700	250	71

EC Centrifugal Fan backward Curved $\varnothing 133 \times 63 \text{mm}$

Backward Curved Centrifugal Fans

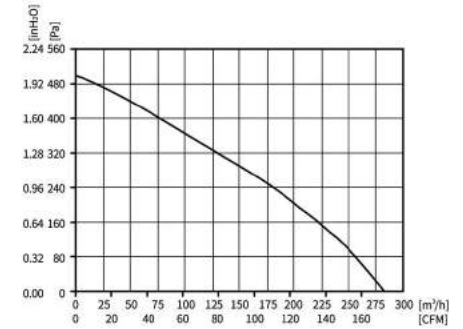

Motor Type EC BRUSHLESS EXTERNAL ROTOR MOTOR	Speed Control 0-10VDC/PWM	Protection Type IP55	Insulation Class B	Operating Temperature -25°C ~ +60°C	Weight 0.6KG	Wiring Mode E1
---	------------------------------	-------------------------	-----------------------	--	-----------------	-------------------

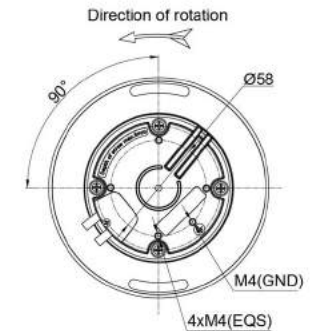
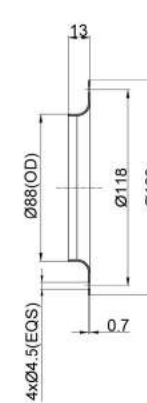
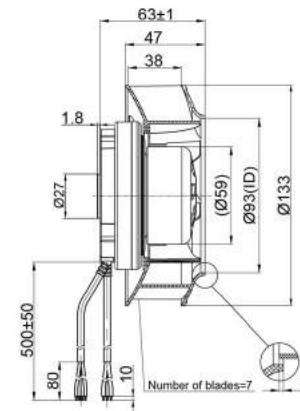

Model	Motor	Bearing System	Rated Voltage	Frequency	Rated Current	Rated Power	Rated Speed	Air Flow	Air Pressure	Sound Level
Part No.	Type	B/S	VAC	Hz	A	W	RPM	M³/H	Pa	dB(A)
PB3N133B2E-FZ5	BE59EC	BALL	230	50/60	0.25	34	4450	280	500	65

EC Centrifugal Fan backward Curved Ø133x63mm

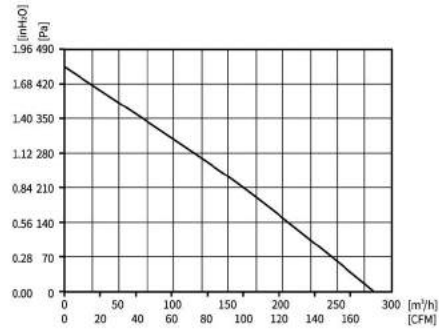

Motor Type EC BRUSHLESS EXTERNAL ROTOR MOTOR	Speed Control 0-10VDC/PWM	Protection Type IP55	Insulation Class B	Operating Temperature -25°C~+60°C	Weight 0.6KG	Wiring Mode E1
---	------------------------------	-------------------------	-----------------------	--------------------------------------	-----------------	-------------------

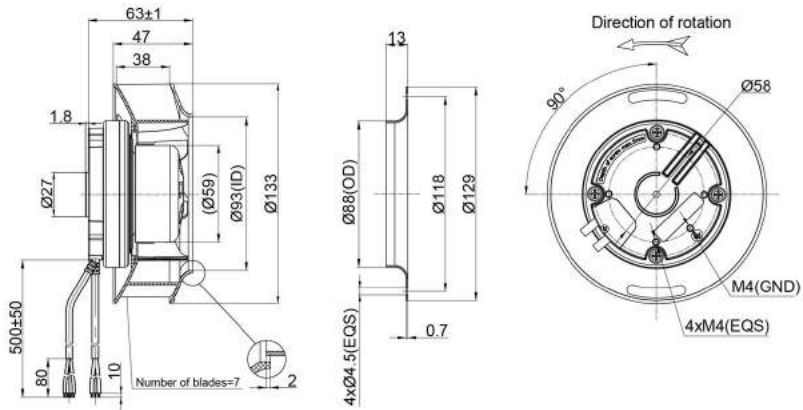

Model	Motor	Bearing System	Rated Voltage	Frequency	Rated Current	Rated Power	Rated Speed	Air Flow	Air Pressure	Sound Level
Part No.	Type	B/S	VAC	Hz	A	W	RPM	M ³ /H	Pa	dB(A)
PB3N133B2E-FZ0	BE59EC	BALL	230	50/60	0.2	30	4250	281	459	64

EC Centrifugal Fan backward Curved Ø133x110mm

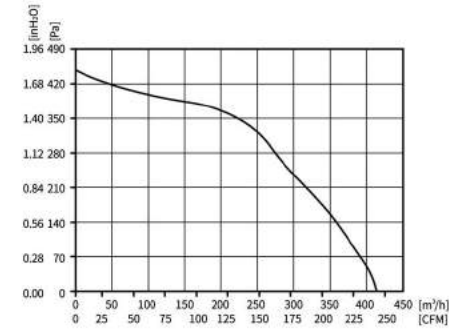

Motor Type EC BRUSHLESS EXTERNAL ROTOR MOTOR	Speed Control 0-10VDC/PWM	Protection Type IP55	Insulation Class B	Operating Temperature -25°C~+60°C	Weight 0.65KG	Wiring Mode E1
---	------------------------------	-------------------------	-----------------------	--------------------------------------	------------------	-------------------

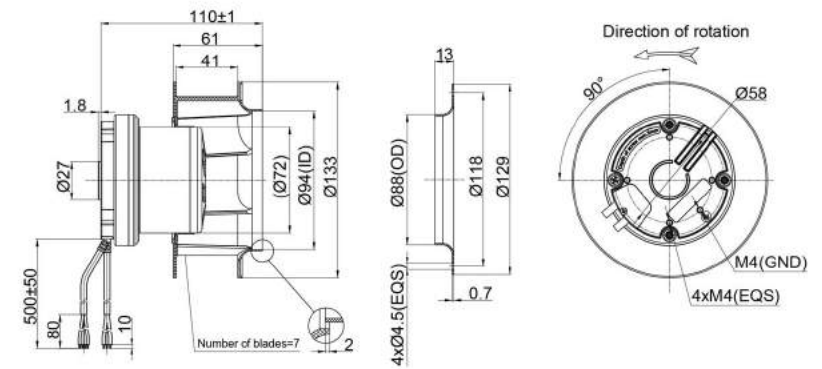

Model	Motor	Bearing System	Rated Voltage	Frequency	Rated Current	Rated Power	Rated Speed	Air Flow	Air Pressure	Sound Level
Part No.	Type	B/S	VAC	Hz	A	W	RPM	M ³ /H	Pa	dB(A)
PB3N133B2E-RB2	BE72EC	BALL	230	50/60	0.3	43	4400	415	450	70

EC Centrifugal Fan backward Curved Ø175x68.5mm

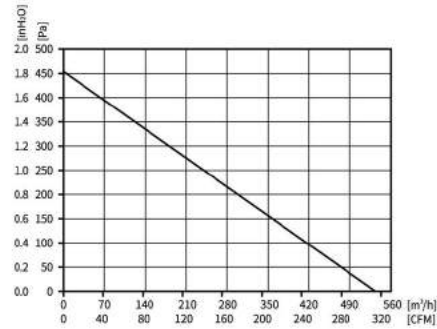

Motor Type EC BRUSHLESS EXTERNAL ROTOR MOTOR	Speed Control 0-10VDC/PWM	Protection Type IP55	Insulation Class B	Operating Temperature -25°C~+60°C	Weight 0.75KG	Wiring Mode E1
---	------------------------------	-------------------------	-----------------------	--------------------------------------	------------------	-------------------

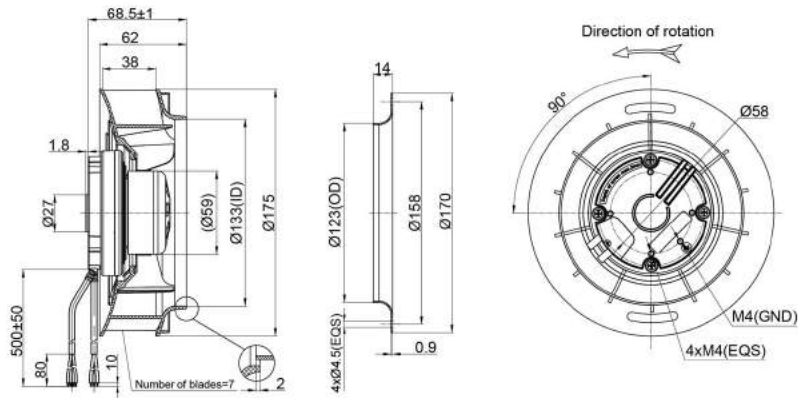

Model	Motor	Bearing System	Rated Voltage	Frequency	Rated Current	Rated Power	Rated Speed	Air Flow	Air Pressure	Sound Level
Part No.	Type	B/S	VAC	Hz	A	W	RPM	M ³ /H	Pa	dB(A)
PB3N175B2E-F25	BE59EC	BALL	230	50/60	0.3	40	3200	535	451	65

EC Centrifugal Fan backward Curved Ø175x68.5mm

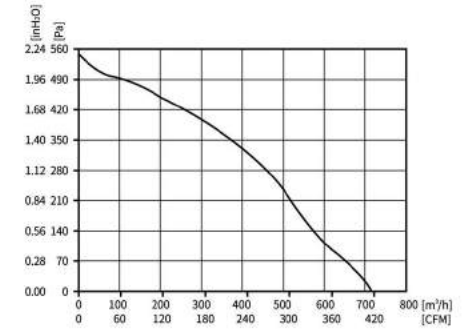

Motor Type EC BRUSHLESS EXTERNAL ROTOR MOTOR	Speed Control 0-10VDC/PWM	Protection Type IP55	Insulation Class B	Operating Temperature -25°C~+60°C	Weight 1.3KG	Wiring Mode E1
---	------------------------------	-------------------------	-----------------------	--------------------------------------	-----------------	-------------------

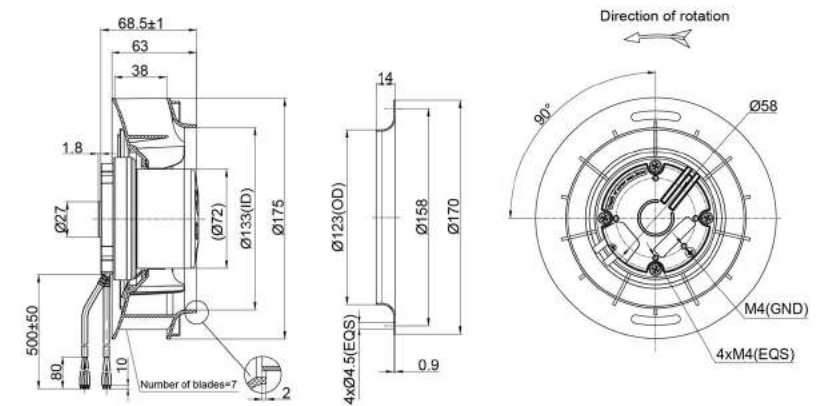

Model	Motor	Bearing System	Rated Voltage	Frequency	Rated Current	Rated Power	Rated Speed	Air Flow	Air Pressure	Sound Level
Part No.	Type	B/S	VAC	Hz	A	W	RPM	M ³ /H	Pa	dB(A)
PB3N175B2E-R20	BE72EC	BALL	230	50/60	0.6	72	4050	710	550	72

EC Centrifugal Fan backward Curved Ø175x68.5mm

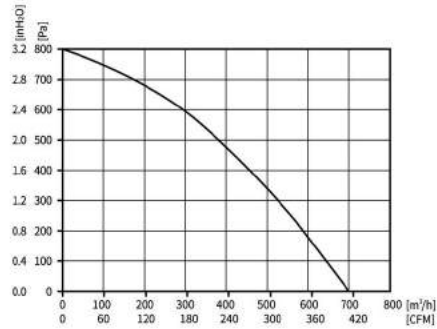

Motor Type	Speed Control	Protection Type	Insulation Class	Operating Temperature	Weight	Wiring Mode
EC BRUSHLESS EXTERNAL ROTOR MOTOR	0-10VDC/PWM	IP55	B	-25°C~+60°C	1.5KG	E1

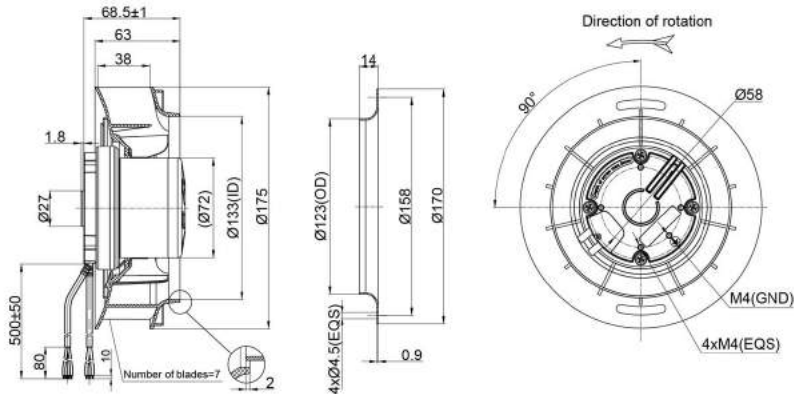

Model	Motor	Bearing System	Rated Voltage	Frequency	Rated Current	Rated Power	Rated Speed	Air Flow	Air Pressure	Sound Level
Part No.	Type	B/S	VAC	Hz	A	W	RPM	M ³ /H	Pa	dB(A)
PB3N175B2E-SZ0	BE72EC	BALL	230	50/60	0.75	110	4600	700	800	74

EC Centrifugal Fan backward Curved Ø190x68.5mm

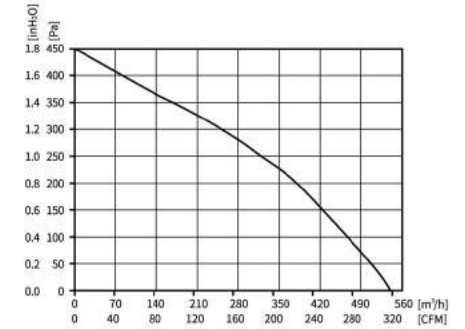

Motor Type	Speed Control	Protection Type	Insulation Class	Operating Temperature	Weight	Wiring Mode
EC BRUSHLESS EXTERNAL ROTOR MOTOR	0-10VDC/PWM	IP55	B	-25°C~+60°C	1.35KG	E1

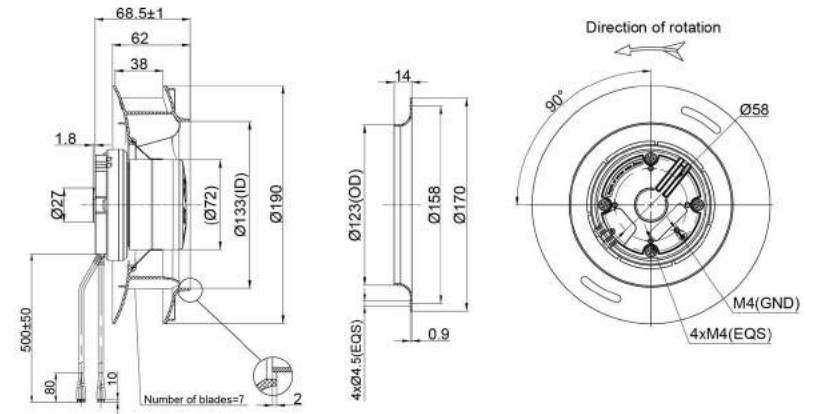

Model	Motor	Bearing System	Rated Voltage	Frequency	Rated Current	Rated Power	Rated Speed	Air Flow	Air Pressure	Sound Level
Part No.	Type	B/S	VAC	Hz	A	W	RPM	M ³ /H	Pa	dB(A)
PB3N190B2E-RZ0	BE72EC	BALL	230	50/60	0.4	52	2940	540	450	65

EC Centrifugal Fan backward Curved Ø190x68.5mm

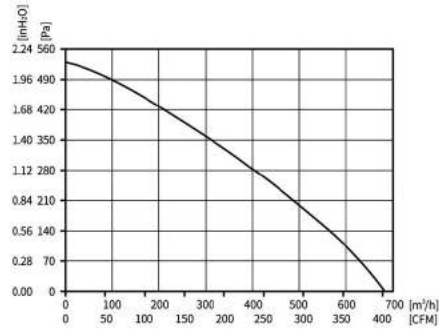

Motor Type EC BRUSHLESS EXTERNAL ROTOR MOTOR	Speed Control 0-10VDC/PWM	Protection Type IP55	Insulation Class B	Operating Temperature -25°C~+60°C	Weight 1.35KG	Wiring Mode E1
---	------------------------------	-------------------------	-----------------------	--------------------------------------	------------------	-------------------

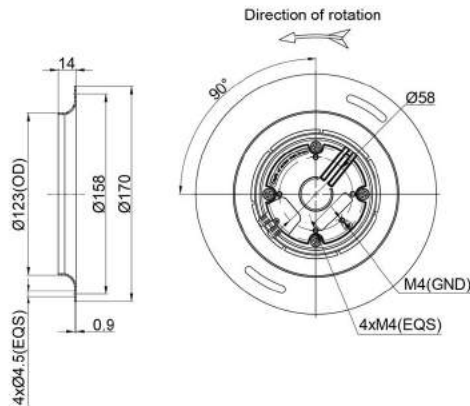
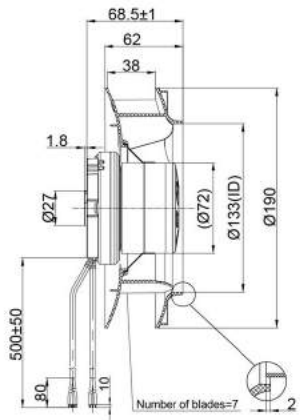

Model	Motor	Bearing System	Rated Voltage	Frequency	Rated Current	Rated Power	Rated Speed	Air Flow	Air Pressure	Sound Level
Part No.	Type	B/S	VAC	Hz	A	W	RPM	M³/H	Pa	dB(A)
PB3N190B2E-RZ1	BE72EC	BALL	230	50/60	0.6	70	3300	685	530	68

EC Centrifugal Fan backward Curved Ø190x68.5mm

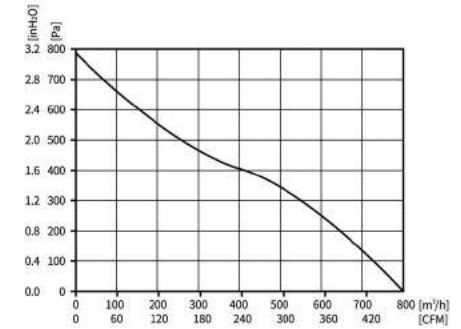

Motor Type EC BRUSHLESS EXTERNAL ROTOR MOTOR	Speed Control 0-10VDC/PWM	Protection Type IP55	Insulation Class B	Operating Temperature -25°C~+60°C	Weight 1.35KG	Wiring Mode E1
---	------------------------------	-------------------------	-----------------------	--------------------------------------	------------------	-------------------

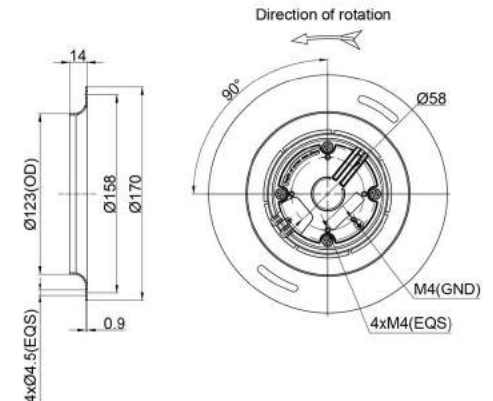
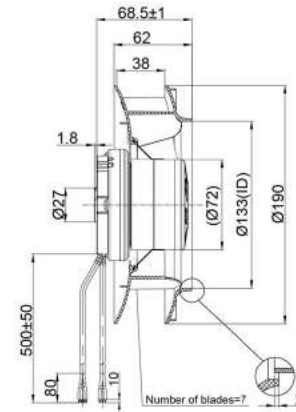

Model	Motor	Bearing System	Rated Voltage	Frequency	Rated Current	Rated Power	Rated Speed	Air Flow	Air Pressure	Sound Level
Part No.	Type	B/S	VAC	Hz	A	W	RPM	M³/H	Pa	dB(A)
PB3N190B2E-RZ2	BE72EC	BALL	230	50/60	0.9	110	3700	800	790	70

EC Centrifugal Fan backward Curved Ø190x68.5mm

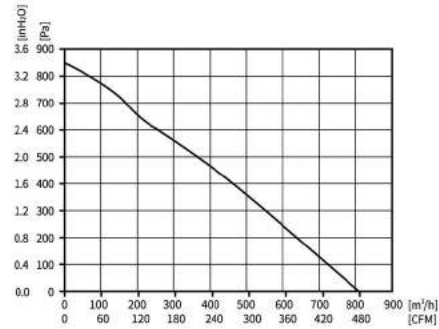

Motor Type EC BRUSHLESS EXTERNAL ROTOR MOTOR	Speed Control 0-10VDC/PWM	Protection Type IP55	Insulation Class B	Operating Temperature -25°C~+60°C	Weight 1.45KG	Wiring Mode E1
---	------------------------------	-------------------------	-----------------------	--------------------------------------	------------------	-------------------

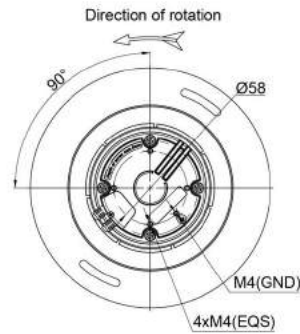
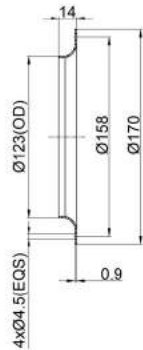
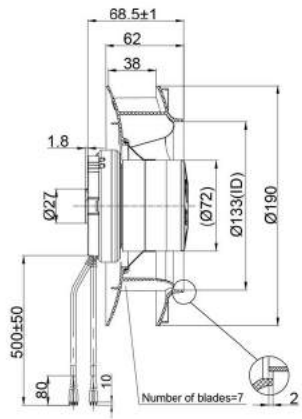

Model	Motor	Bearing System	Rated Voltage	Frequency	Rated Current	Rated Power	Rated Speed	Air Flow	Air Pressure	Sound Level
Part No.	Type	B/S	VAC	Hz	A	W	RPM	M³/H	Pa	dB(A)
PB3N190B2E-SZ0	BE72EC	BALL	230	50/60	0.8	110	3800	810	850	71

EC Centrifugal Fan backward Curved Ø190x88mm

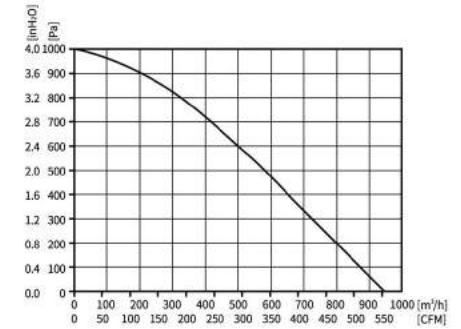

Motor Type EC BRUSHLESS EXTERNAL ROTOR MOTOR	Speed Control 0-10VDC/PWM	Protection Type IP55	Insulation Class B	Operating Temperature -25°C~+60°C	Weight 1.85KG	Wiring Mode E1
---	------------------------------	-------------------------	-----------------------	--------------------------------------	------------------	-------------------

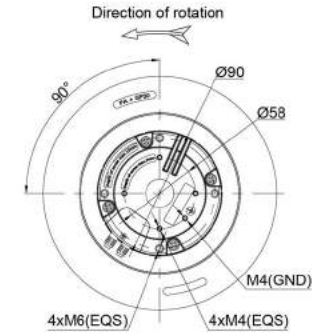
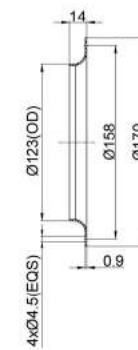
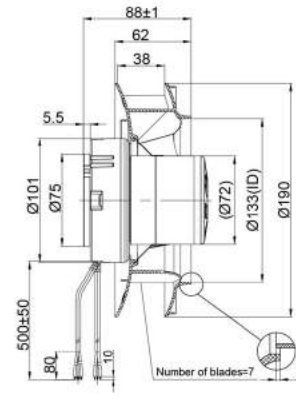

Model	Motor	Bearing System	Rated Voltage	Frequency	Rated Current	Rated Power	Rated Speed	Air Flow	Air Pressure	Sound Level
Part No.	Type	B/S	VAC	Hz	A	W	RPM	M³/H	Pa	dB(A)
PB3N190B2E-TZ0	BE72EC	BALL	230	50/60	1.2	170	4550	945	1000	72

EC Centrifugal Fan backward Curved Ø220x71mm

EC Centrifugal Fan backward Curved Ø220x71mm

Backward Curved Centrifugal Fans

Backward Curved Centrifugal Fans

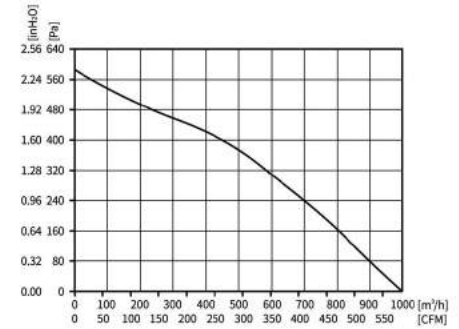
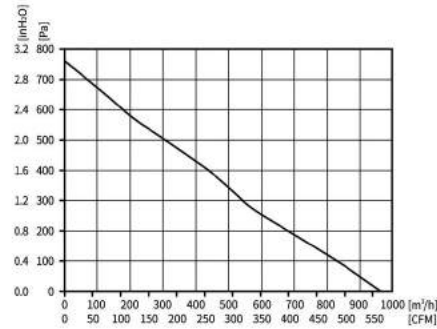

Motor Type EC BRUSHLESS EXTERNAL ROTOR MOTOR	Speed Control 0-10VDC/PWM	Protection Type IP55	Insulation Class B	Operating Temperature -25°C~+60°C	Weight 1.6KG	Wiring Mode E1
---	------------------------------	-------------------------	-----------------------	--------------------------------------	-----------------	-------------------

Motor Type EC BRUSHLESS EXTERNAL ROTOR MOTOR	Speed Control 0-10VDC/PWM	Protection Type IP55	Insulation Class B	Operating Temperature -25°C~+60°C	Weight 1.7KG	Wiring Mode E1
---	------------------------------	-------------------------	-----------------------	--------------------------------------	-----------------	-------------------

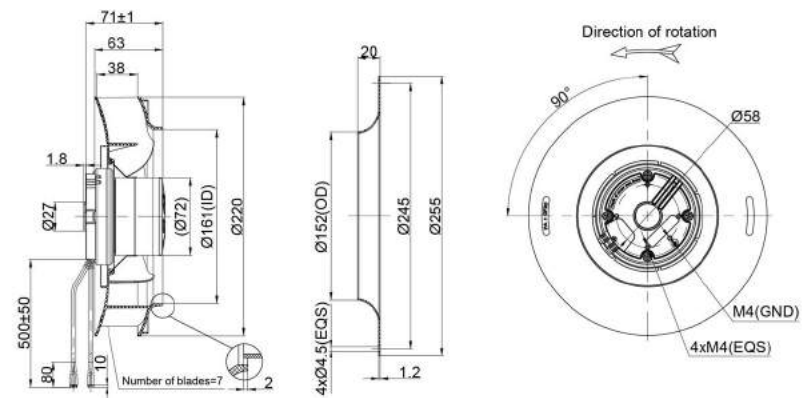
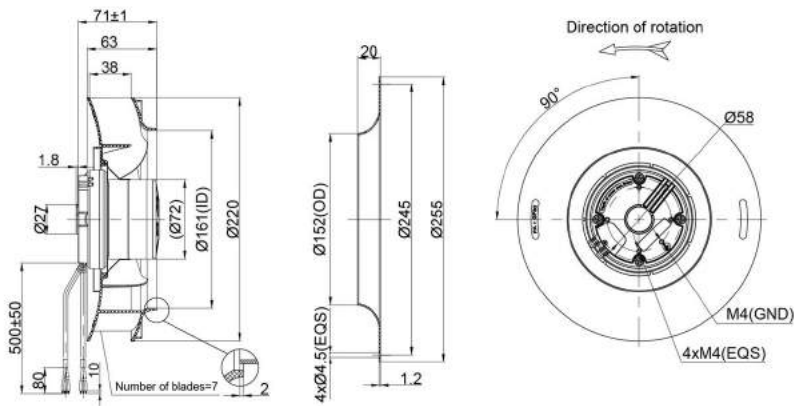

Model	Motor	Bearing System	Rated Voltage	Frequency	Rated Current	Rated Power	Rated Speed	Air Flow	Air Pressure	Sound Level
Part No.	Type	B/S	VAC	Hz	A	W	RPM	M ³ /H	Pa	dB(A)
PB3N220B2E-RZ0	BE72EC	BALL	230	50/60	0.65	85	2670	960	760	68

Model	Motor	Bearing System	Rated Voltage	Frequency	Rated Current	Rated Power	Rated Speed	Air Flow	Air Pressure	Sound Level
Part No.	Type	B/S	VAC	Hz	A	W	RPM	M ³ /H	Pa	dB(A)
PB3N220B2E-SZ0	BE72EC	BALL	230	50/60	0.8	110	3100	1000	580	69

EC Centrifugal Fan backward Curved Ø225x99mm

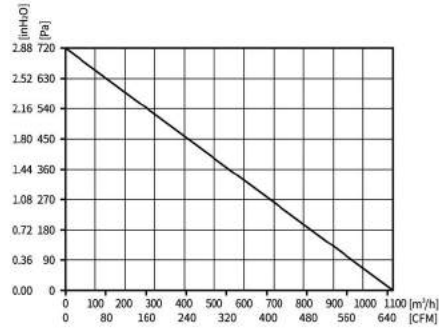

Motor Type EC BRUSHLESS EXTERNAL ROTOR MOTOR	Speed Control 0-10VDC/PWM	Protection Type IP55	Insulation Class B	Operating Temperature -25°C~+60°C	Weight 1.52KG	Wiring Mode E2
---	------------------------------	-------------------------	-----------------------	--------------------------------------	------------------	-------------------

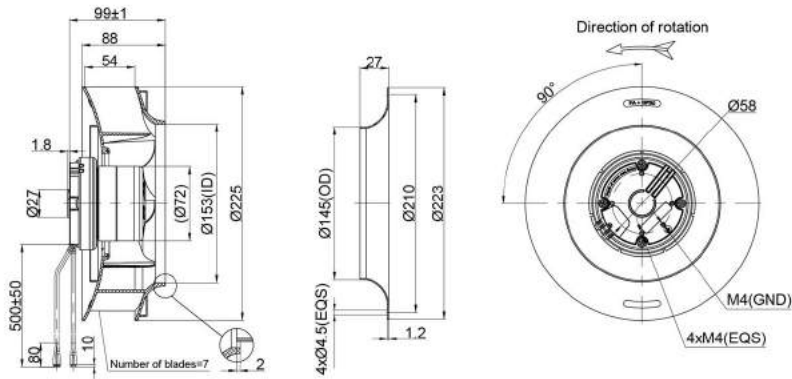

Model	Motor	Bearing System	Rated Voltage	Frequency	Rated Current	Rated Power	Rated Speed	Air Flow	Air Pressure	Sound Level
Part No.	Type	B/S	VAC	Hz	A	W	RPM	M³/H	Pa	dB(A)
PB3N225B2E-RG1	BE72EC	BALL	230	50/60	0.75	100	2450	1100	720	66

EC Centrifugal Fan backward Curved Ø225x99mm

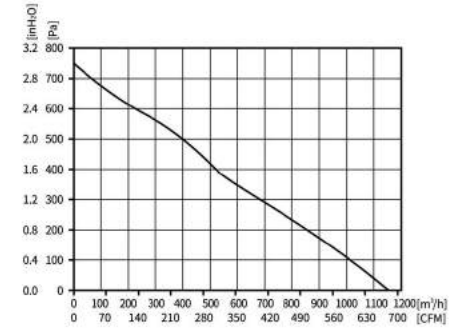

Motor Type EC BRUSHLESS EXTERNAL ROTOR MOTOR	Speed Control 0-10VDC/PWM	Protection Type IP55	Insulation Class B	Operating Temperature -25°C~+60°C	Weight 1.65KG	Wiring Mode E1
---	------------------------------	-------------------------	-----------------------	--------------------------------------	------------------	-------------------

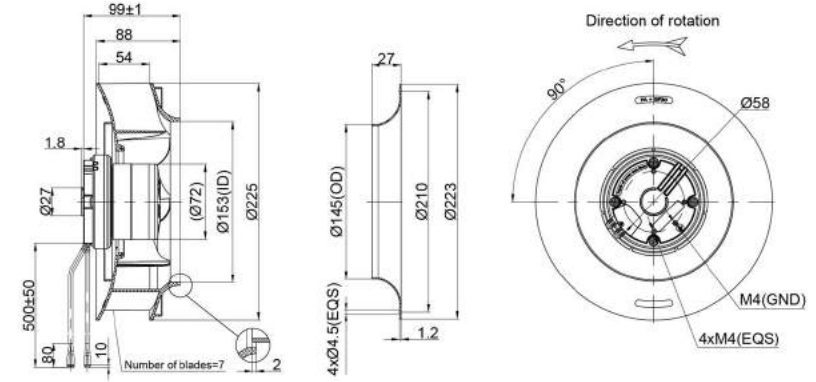

Model	Motor	Bearing System	Rated Voltage	Frequency	Rated Current	Rated Power	Rated Speed	Air Flow	Air Pressure	Sound Level
Part No.	Type	B/S	VAC	Hz	A	W	RPM	M³/H	Pa	dB(A)
PB3N225B2E-SG0	BE72EC	BALL	230	50/60	0.8	110	2600	1150	750	68

EC Centrifugal Fan backward Curved Ø225x99mm

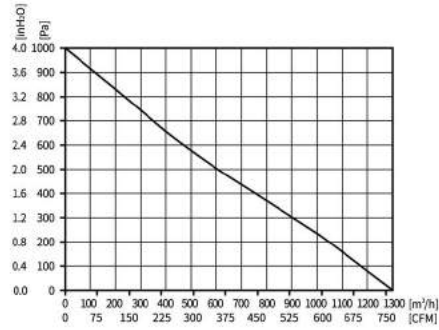

Motor Type EC BRUSHLESS EXTERNAL ROTOR MOTOR	Speed Control 0-10VDC/PWM	Protection Type IP55	Insulation Class B	Operating Temperature -25°C~+60°C	Weight 2.47KG	Wiring Mode E1
---	------------------------------	-------------------------	-----------------------	--------------------------------------	------------------	-------------------

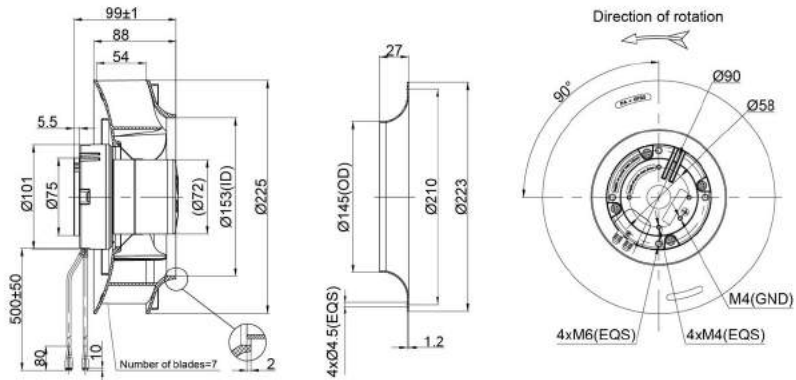

Model	Motor	Bearing System	Rated Voltage	Frequency	Rated Current	Rated Power	Rated Speed	Air Flow	Air Pressure	Sound Level
Part No.	Type	B/S	VAC	Hz	A	W	RPM	M ³ /H	Pa	dB(A)
PB3N225B2E-TG0	BE72EC	BALL	230	50/60	1.2	170	3200	1300	1000	71

EC Centrifugal Fan backward Curved Ø225x99mm

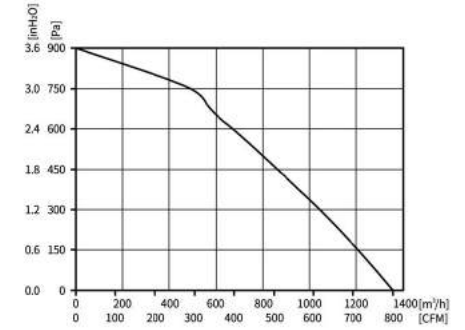

Motor Type EC BRUSHLESS EXTERNAL ROTOR MOTOR	Speed Control 0-10VDC/PWM	Protection Type IP55	Insulation Class B	Operating Temperature -25°C~+60°C	Weight 3.1KG	Wiring Mode E2
---	------------------------------	-------------------------	-----------------------	--------------------------------------	-----------------	-------------------

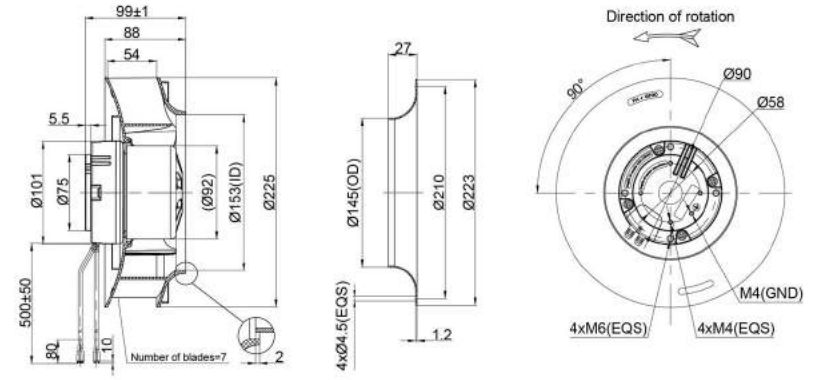

Model	Motor	Bearing System	Rated Voltage	Frequency	Rated Current	Rated Power	Rated Speed	Air Flow	Air Pressure	Sound Level
Part No.	Type	B/S	VAC	Hz	A	W	RPM	M ³ /H	Pa	dB(A)
PB3N225B2E-MG0	BE92EC	BALL	230	50/60	1.6	220	3500	1350	900	72

EC Centrifugal Fan backward Curved Ø250x99mm

EC Centrifugal Fan backward Curved Ø250x99mm

Backward Curved Centrifugal Fans

Backward Curved Centrifugal Fans

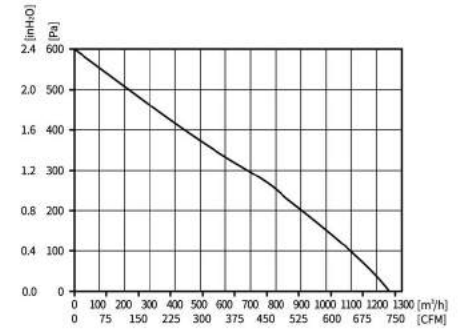
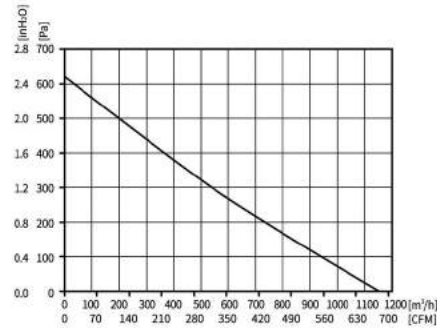

Motor Type EC BRUSHLESS EXTERNAL ROTOR MOTOR	Speed Control 0-10VDC/PWM	Protection Type IP55	Insulation Class B	Operating Temperature -25°C~+60°C	Weight 1.72KG	Wiring Mode E1
---	------------------------------	-------------------------	-----------------------	--------------------------------------	------------------	-------------------

Motor Type EC BRUSHLESS EXTERNAL ROTOR MOTOR	Speed Control 0-10VDC/PWM	Protection Type IP55	Insulation Class B	Operating Temperature -25°C~+60°C	Weight 1.82KG	Wiring Mode E1
---	------------------------------	-------------------------	-----------------------	--------------------------------------	------------------	-------------------

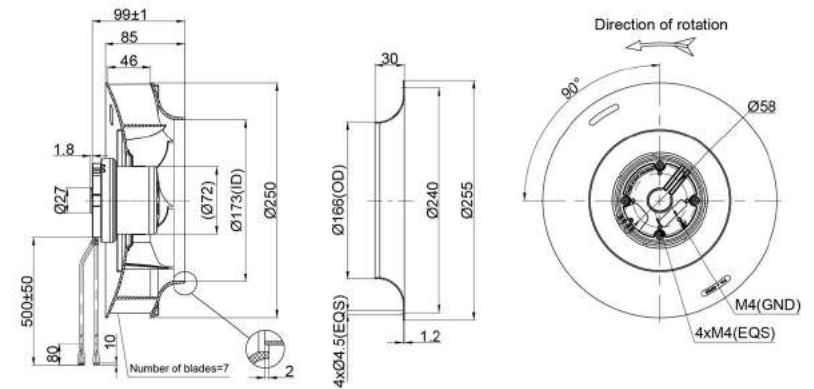
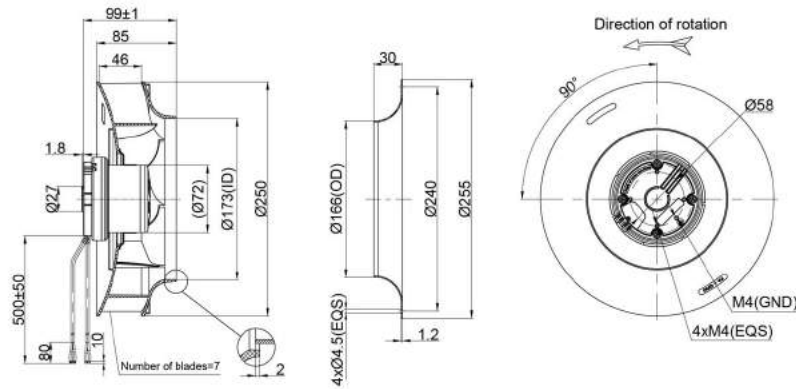

Model	Motor	Bearing System	Rated Voltage	Frequency	Rated Current	Rated Power	Rated Speed	Air Flow	Air Pressure	Sound Level
Part No.	Type	B/S	VAC	Hz	A	W	RPM	M ³ /H	Pa	dB(A)
PB3N250B2E-RZ0	BE72EC	BALL	230	50/60	0.65	85	2100	1150	610	62

Model	Motor	Bearing System	Rated Voltage	Frequency	Rated Current	Rated Power	Rated Speed	Air Flow	Air Pressure	Sound Level
Part No.	Type	B/S	VAC	Hz	A	W	RPM	M ³ /H	Pa	dB(A)
PB3N250B2E-SZ0	BE72EC	BALL	230	50/60	0.85	115	2350	1250	600	68

EC Centrifugal Fan backward Curved Ø250x99mm

EC Centrifugal Fan backward Curved Ø250x99mm

Backward Curved Centrifugal Fans

Backward Curved Centrifugal Fans

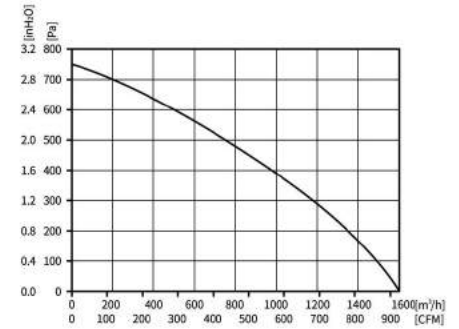
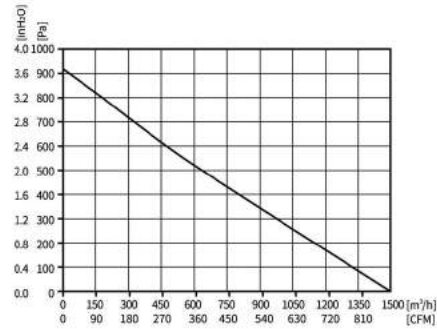

Motor Type EC BRUSHLESS EXTERNAL ROTOR MOTOR	Speed Control 0-10VDC/PWM	Protection Type IP55	Insulation Class B	Operating Temperature -25°C ~ +60°C	Weight 2.42KG	Wiring Mode E1
---	------------------------------	-------------------------	-----------------------	--	------------------	-------------------

Motor Type EC BRUSHLESS EXTERNAL ROTOR MOTOR	Speed Control 0-10VDC/PWM	Protection Type IP55	Insulation Class B	Operating Temperature -25°C ~ +60°C	Weight 3.42KG	Wiring Mode E2
---	------------------------------	-------------------------	-----------------------	--	------------------	-------------------

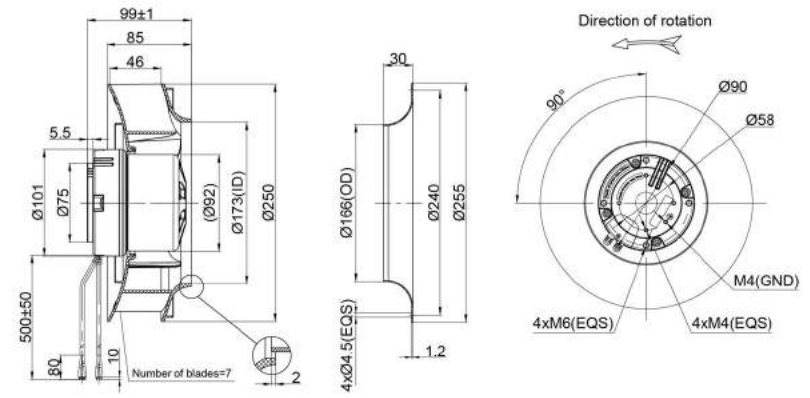
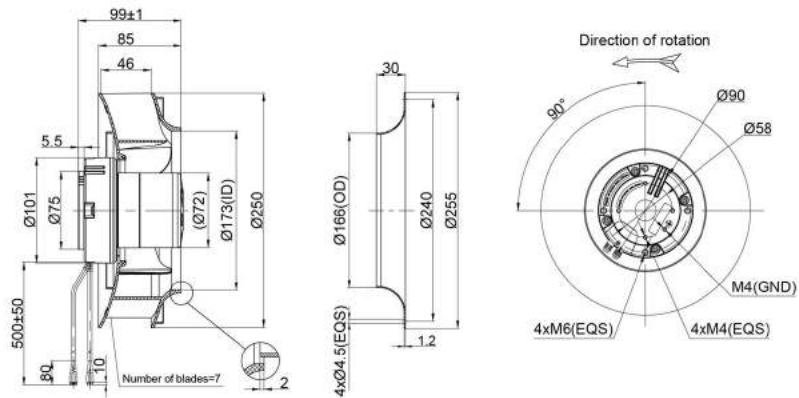

Model	Motor	Bearing System	Rated Voltage	Frequency	Rated Current	Rated Power	Rated Speed	Air Flow	Air Pressure	Sound Level
Part No.	Type	B/S	VAC	Hz	A	W	RPM	M ³ /H	Pa	dB(A)
PB3N250B2E-TZ0	BE72EC	BALL	230	50/60	1.2	170	2750	1500	915	71

Model	Motor	Bearing System	Rated Voltage	Frequency	Rated Current	Rated Power	Rated Speed	Air Flow	Air Pressure	Sound Level
Part No.	Type	B/S	VAC	Hz	A	W	RPM	M ³ /H	Pa	dB(A)
PB3N250B2E-MZ0	BE92EC	BALL	230	50/60	1.6	220	3100	1600	750	72

EC Centrifugal Fan backward Curved Ø250x210.5mm

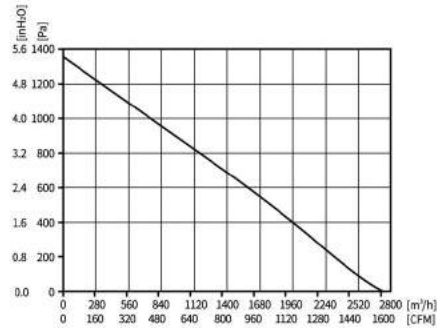

Motor Type EC BRUSHLESS EXTERNAL ROTOR MOTOR	Speed Control 0-10VDC/PWM	Protection Type IP55	Insulation Class F	Operating Temperature -25°C~+60°C	Weight 5.91KG	Wiring Mode E3
---	------------------------------	-------------------------	-----------------------	--------------------------------------	------------------	-------------------

EC Centrifugal Fan backward Curved Ø250x210.5mm

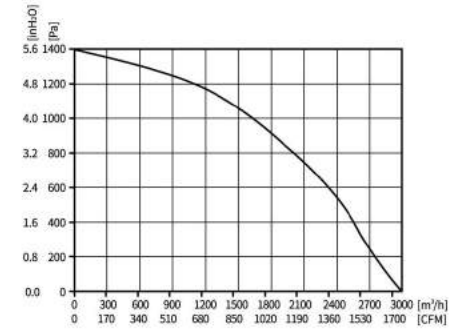

Motor Type EC BRUSHLESS EXTERNAL ROTOR MOTOR	Speed Control 0-10VDC/PWM	Protection Type IP55	Insulation Class F	Operating Temperature -25°C~+60°C	Weight 5.91KG	Wiring Mode E4
---	------------------------------	-------------------------	-----------------------	--------------------------------------	------------------	-------------------

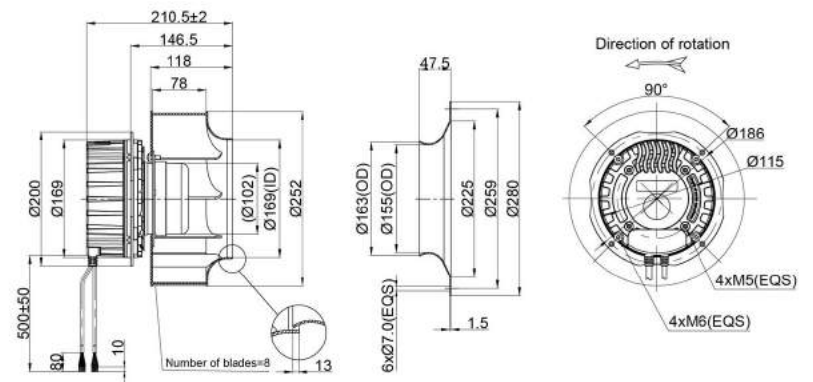
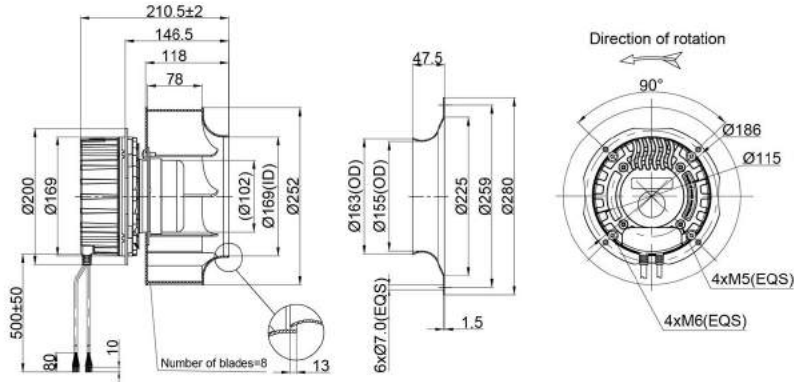

Model	Motor	Bearing System	Rated Voltage	Frequency	Rated Current	Rated Power	Rated Speed	Air Flow	Air Pressure	Sound Level
Part No.	Type	B/S	VAC	Hz	A	W	RPM	M ³ /H	Pa	dB(A)
PB3N250B2E-YZ5	BE102EC	BALL	230	50/60	2.5	550	3600	2750	1330	85

Model	Motor	Bearing System	Rated Voltage	Frequency	Rated Current	Rated Power	Rated Speed	Air Flow	Air Pressure	Sound Level
Part No.	Type	B/S	VAC	Hz	A	W	RPM	M ³ /H	Pa	dB(A)
PB3N250B4E-YZ5	BE102EC	BALL	380	50/60	1.17	750	4100	3000	1400	91

EC Centrifugal Fan backward Curved Ø280x119mm

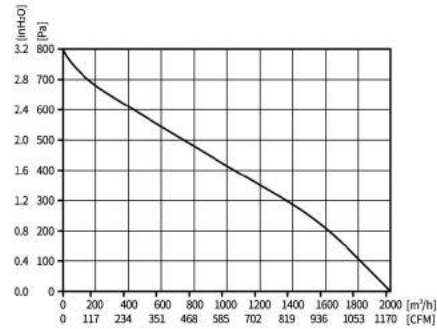

Motor Type EC BRUSHLESS EXTERNAL ROTOR MOTOR	Speed Control 0-10VDC/PWM	Protection Type IP55	Insulation Class B	Operating Temperature -25°C~+60°C	Weight 3.67KG	Wiring Mode E2
---	------------------------------	-------------------------	-----------------------	--------------------------------------	------------------	-------------------

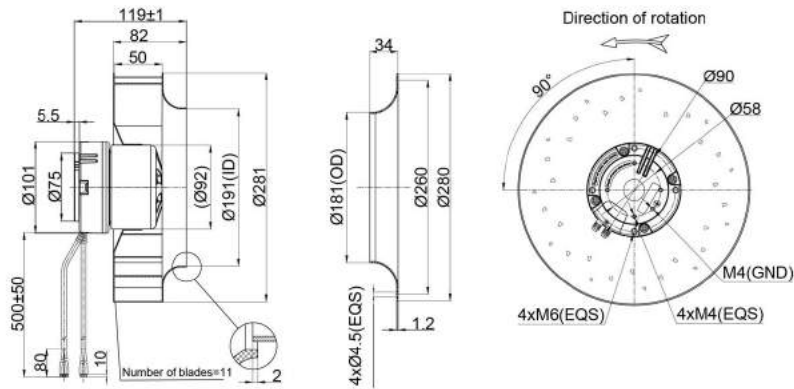

Model	Motor	Bearing System	Rated Voltage	Rated Frequency	Rated Current	Rated Power	Rated Speed	Air Flow	Air Pressure	Sound Level
Part No.	Type	B/S	VAC	Hz	A	W	RPM	M ³ /H	Pa	dB(A)
PB3N280B2E-MZ0	BE92EC	BALL	230	50/60	1.5	210	2600	2000	800	70

EC Centrifugal Fan backward Curved Ø280x225.5mm

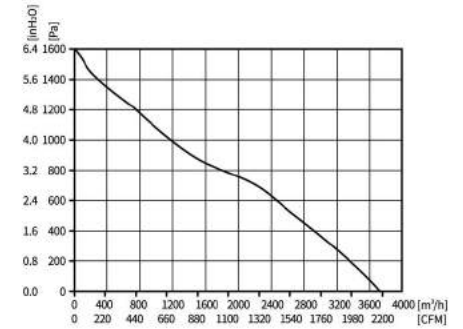

Motor Type EC BRUSHLESS EXTERNAL ROTOR MOTOR	Speed Control 0-10VDC/PWM	Protection Type IP55	Insulation Class F	Operating Temperature -25°C~+60°C	Weight 6.4KG	Wiring Mode E3
---	------------------------------	-------------------------	-----------------------	--------------------------------------	-----------------	-------------------

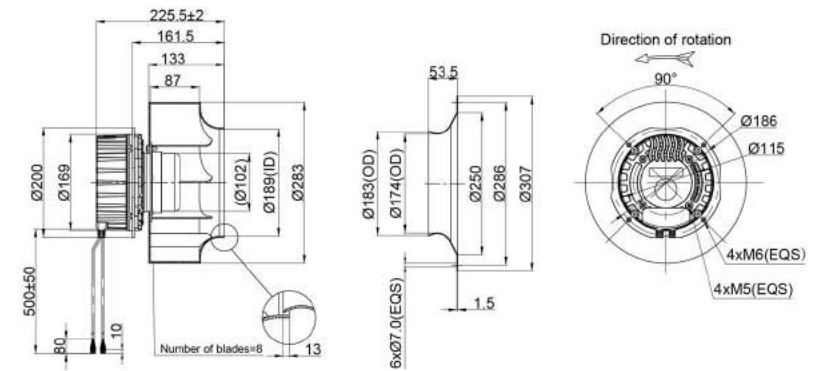

Model	Motor	Bearing System	Rated Voltage	Rated Frequency	Rated Current	Rated Power	Rated Speed	Air Flow	Air Pressure	Sound Level
Part No.	Type	B/S	VAC	Hz	A	W	RPM	M ³ /H	Pa	dB(A)
PB3N280B2E-YZ5	BE102EC	BALL	230	50/60	3.1	700	3300	3720	1600	85

EC Centrifugal Fan backward Curved Ø280x225.5mm

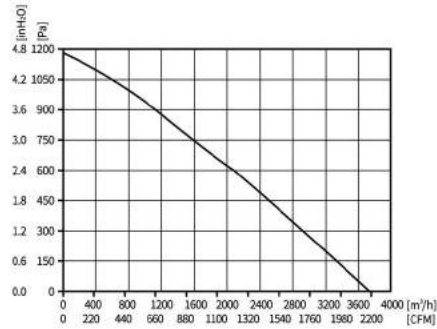

Motor Type EC BRUSHLESS EXTERNAL ROTOR MOTOR	Speed Control 0-10VDC/PWM	Protection Type IP55	Insulation Class F	Operating Temperature -25°C~+60°C	Weight 6.4KG	Wiring Mode E4
---	------------------------------	-------------------------	-----------------------	--------------------------------------	-----------------	-------------------

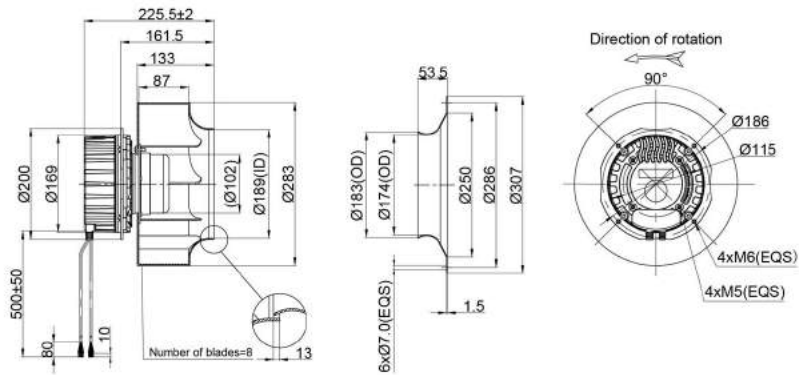

Model	Motor	Bearing System	Rated Voltage	Frequency	Rated Current	Rated Power	Rated Speed	Air Flow	Air Pressure	Sound Level
Part No.	Type	B/S	VAC	Hz	A	W	RPM	M³/H	Pa	dB(A)
PB3N280B4E-YZ5	BE102EC	BALL	380	50/60	1.26	800	3400	3700	1180	93

EC Centrifugal Fan backward Curved Ø310x133.5mm

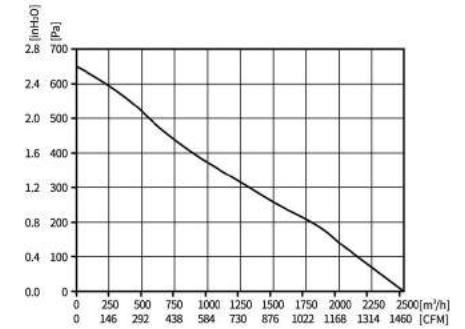

Motor Type EC BRUSHLESS EXTERNAL ROTOR MOTOR	Speed Control 0-10VDC/PWM	Protection Type IP55	Insulation Class B	Operating Temperature -25°C~+60°C	Weight 3.94KG	Wiring Mode E2
---	------------------------------	-------------------------	-----------------------	--------------------------------------	------------------	-------------------

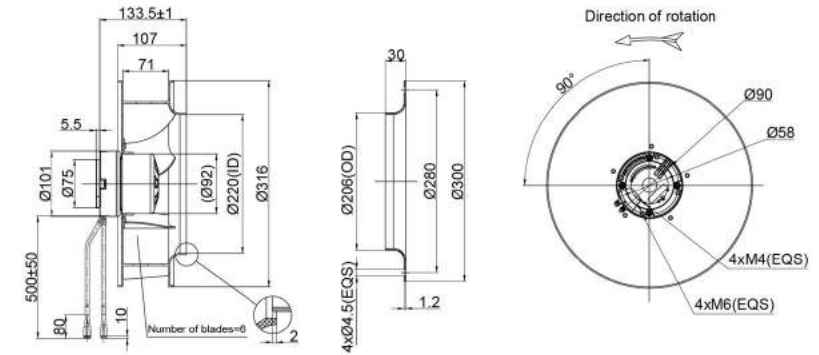

Model	Motor	Bearing System	Rated Voltage	Frequency	Rated Current	Rated Power	Rated Speed	Air Flow	Air Pressure	Sound Level
Part No.	Type	B/S	VAC	Hz	A	W	RPM	M³/H	Pa	dB(A)
PB3N310B2E-MZ0	BE92EC	BALL	230	50/60	1.55	220	2100	2500	650	66

EC Centrifugal Fan backward Curved Ø310x221mm

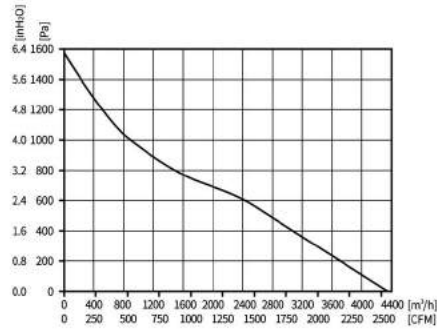

Motor Type EC BRUSHLESS EXTERNAL ROTOR MOTOR	Speed Control 0-10VDC/PWM	Protection Type IP55	Insulation Class F	Operating Temperature -25°C~+60°C	Weight 6.77KG	Wiring Mode E3
---	------------------------------	-------------------------	-----------------------	--------------------------------------	------------------	-------------------

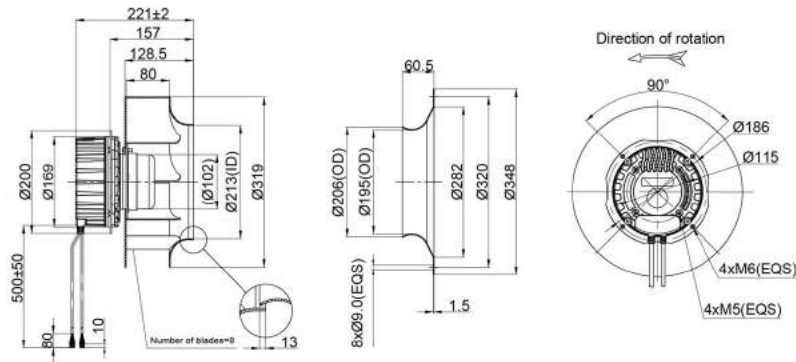

Model	Motor	Bearing System	Rated Voltage	Frequency	Rated Current	Rated Power	Rated Speed	Air Flow	Air Pressure	Sound Level
Part No.	Type	B/S	VAC	Hz	A	W	RPM	M³/H	Pa	dB(A)
PB3N310B2E-YZ5	BE102EC	BALL	230	50/60	3.1	700	2850	4380	1590	85

EC Centrifugal Fan backward Curved Ø310x221mm

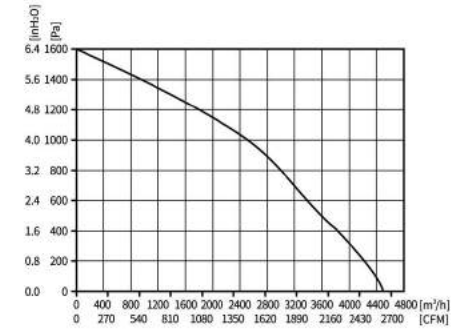

Motor Type EC BRUSHLESS EXTERNAL ROTOR MOTOR	Speed Control 0-10VDC/PWM	Protection Type IP55	Insulation Class F	Operating Temperature -25°C~+60°C	Weight 6.77KG	Wiring Mode E4
---	------------------------------	-------------------------	-----------------------	--------------------------------------	------------------	-------------------

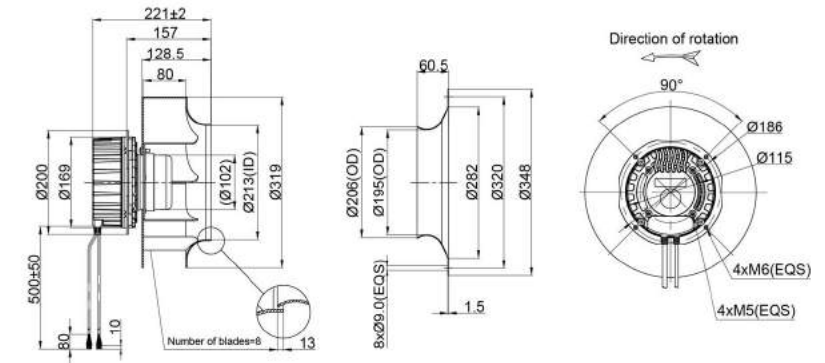

Model	Motor	Bearing System	Rated Voltage	Frequency	Rated Current	Rated Power	Rated Speed	Air Flow	Air Pressure	Sound Level
Part No.	Type	B/S	VAC	Hz	A	W	RPM	M³/H	Pa	dB(A)
PB3N310B4E-YZ5	BE102EC	BALL	380	50/60	1.2	1100	3000	4500	1600	87

EC Centrifugal Fan backward Curved Ø355x257.5mm

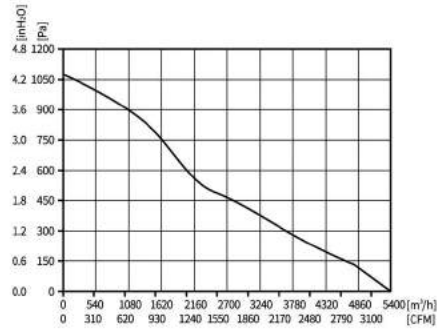

Motor Type EC BRUSHLESS EXTERNAL ROTOR MOTOR	Speed Control 0-10VDC/PWM	Protection Type IP55	Insulation Class F	Operating Temperature -25°C~+60°C	Weight 7.44KG	Wiring Mode E3
---	------------------------------	-------------------------	-----------------------	--------------------------------------	------------------	-------------------

EC Centrifugal Fan backward Curved Ø355x257.5mm

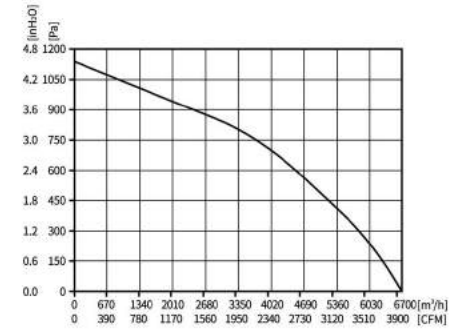

Motor Type EC BRUSHLESS EXTERNAL ROTOR MOTOR	Speed Control 0-10VDC/PWM	Protection Type IP55	Insulation Class F	Operating Temperature -25°C~+60°C	Weight 7.44KG	Wiring Mode E4
---	------------------------------	-------------------------	-----------------------	--------------------------------------	------------------	-------------------

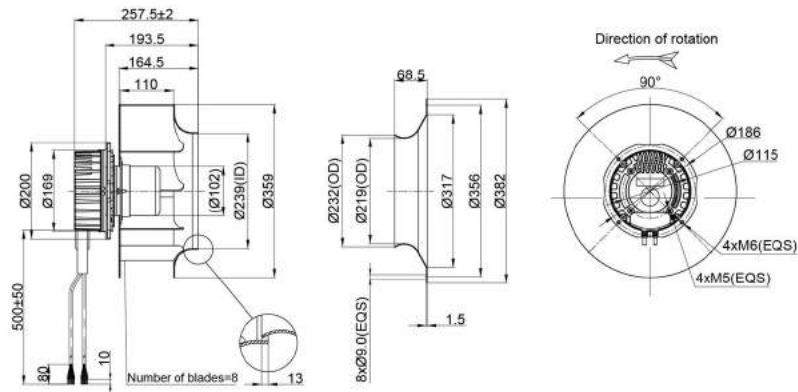

Model	Motor	Bearing System	Rated Voltage	Frequency	Rated Current	Rated Power	Rated Speed	Air Flow	Air Pressure	Sound Level
Part No.	Type	B/S	VAC	Hz	A	W	RPM	M³/H	Pa	dB(A)
PB3N355B2E-ZW5	BE102EC	BALL	230	50/60	3.0	700	2150	5400	1080	84

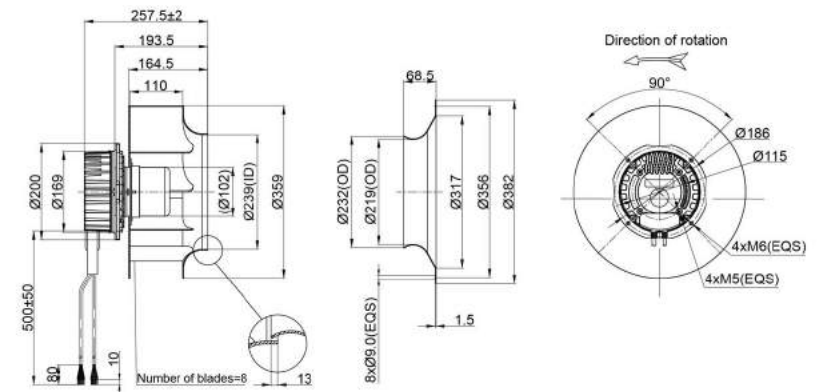

Model	Motor	Bearing System	Rated Voltage	Frequency	Rated Current	Rated Power	Rated Speed	Air Flow	Air Pressure	Sound Level
Part No.	Type	B/S	VAC	Hz	A	W	RPM	M³/H	Pa	dB(A)
PB3N355B4E-ZW5	BE102EC	BALL	380	50/60	1.8	1100	2500	6700	1150	86

EC Centrifugal Fan backward Curved Ø400x278mm

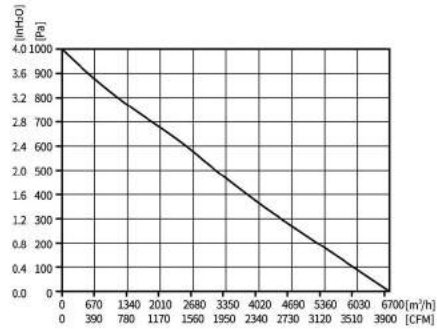

Motor Type EC BRUSHLESS EXTERNAL ROTOR MOTOR	Speed Control 0-10VDC/PWM	Protection Type IP55	Insulation Class F	Operating Temperature -25°C~+60°C	Weight 9.94KG	Wiring Mode E3
---	------------------------------	-------------------------	-----------------------	--------------------------------------	------------------	-------------------

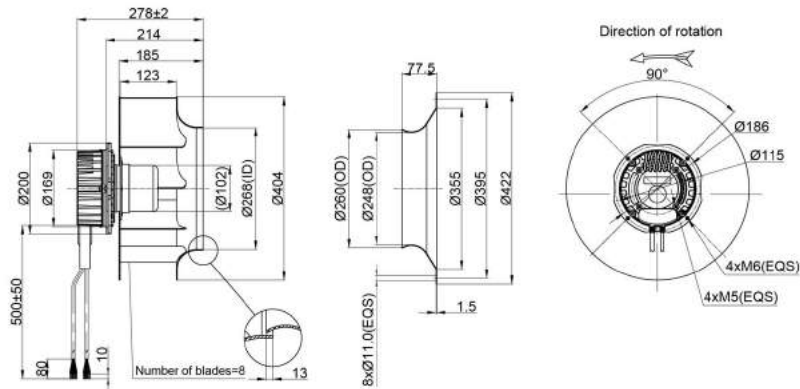

Model Part No.	Motor Type	Bearing System B/S	Rated Voltage VAC	Frequency Hz	Rated Current A	Rated Power W	Rated Speed RPM	Air Flow M³/H	Air Pressure Pa	Sound Level dB(A)
PB3N400B2E-ZW5	BE102EC	BALL	230	50/60	3.1	700	1750	6700	1000	83

EC Centrifugal Fan backward Curved Ø400x278mm

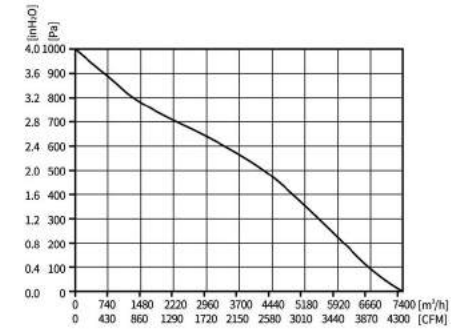

Motor Type EC BRUSHLESS EXTERNAL ROTOR MOTOR	Speed Control 0-10VDC/PWM	Protection Type IP55	Insulation Class F	Operating Temperature -25°C~+60°C	Weight 9.94KG	Wiring Mode E4
---	------------------------------	-------------------------	-----------------------	--------------------------------------	------------------	-------------------

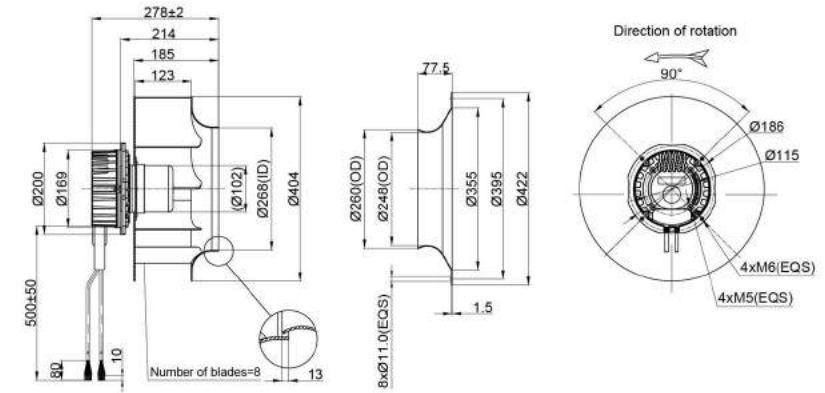

Model Part No.	Motor Type	Bearing System B/S	Rated Voltage VAC	Frequency Hz	Rated Current A	Rated Power W	Rated Speed RPM	Air Flow M³/H	Air Pressure Pa	Sound Level dB(A)
PB3N400B4E-ZW5	BE102EC	BALL	380	50/60	1.2	1300	2000	7400	1000	85

EC Centrifugal Fan backward Curved Ø450x304mm

EC Centrifugal Fan backward Curved Ø450x304mm

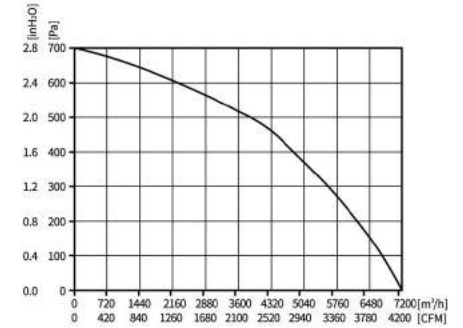
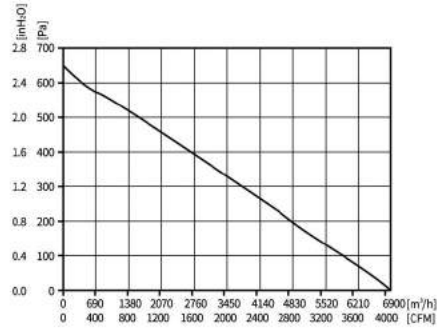

Backward Curved Centrifugal Fans

Backward Curved Centrifugal Fans

Motor Type	Speed Control	Protection Type	Insulation Class	Operating Temperature	Weight	Wiring Mode
EC BRUSHLESS EXTERNAL ROTOR MOTOR	0-10VDC/PWM	IP55	F	-25°C~+60°C	9.23KG	E3

Motor Type	Speed Control	Protection Type	Insulation Class	Operating Temperature	Weight	Wiring Mode
EC BRUSHLESS EXTERNAL ROTOR MOTOR	0-10VDC/PWM	IP55	F	-25°C~+60°C	9.23KG	E4

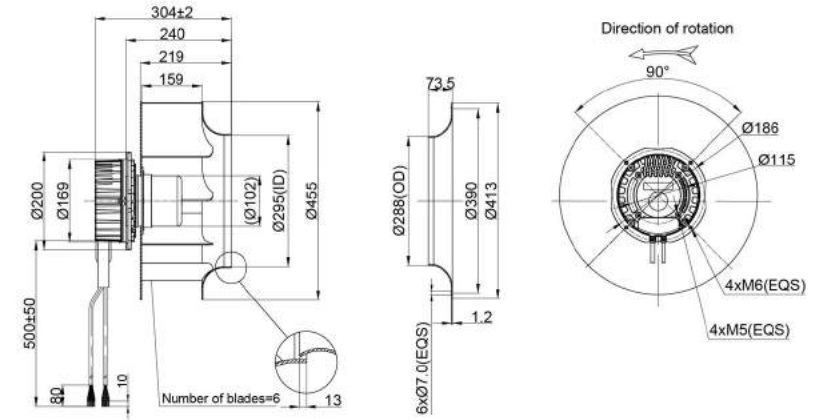
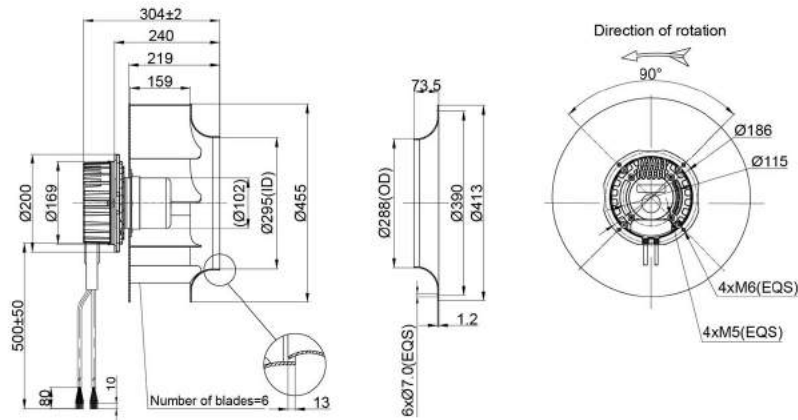

Model	Motor	Bearing System	Rated Voltage	Rated Frequency	Rated Current	Rated Power	Rated Speed	Air Flow	Air Pressure	Sound Level
Part No.	Type	B/S	VAC	Hz	A	W	RPM	M³/H	Pa	dB(A)
PB3N450B2E-ZW5	BE102EC	BALL	230	50/60	3.2	700	1550	6900	650	80

Model	Motor	Bearing System	Rated Voltage	Rated Frequency	Rated Current	Rated Power	Rated Speed	Air Flow	Air Pressure	Sound Level
Part No.	Type	B/S	VAC	Hz	A	W	RPM	M³/H	Pa	dB(A)
PB3N450B4E-ZW5	BE102EC	BALL	380	50/60	1.5	1000	1800	7200	700	83

EC Centrifugal Fan Forward Curved Ø108x80mm

EC Centrifugal Fan Forward Curved Ø120x84mm

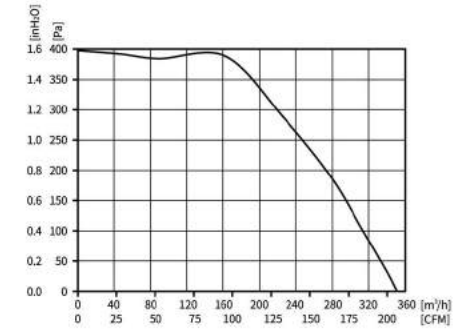
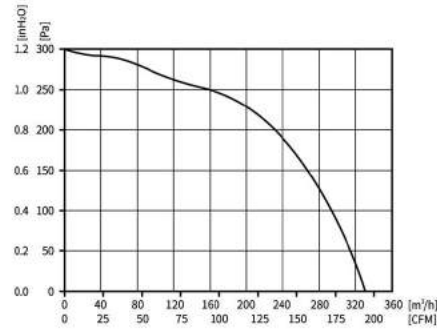

Motor Type	Speed Control	Protection Type	Insulation Class	Operating Temperature	Weight	Wiring Mode
EC BRUSHLESS EXTERNAL ROTOR MOTOR	0-10VDC/PWM	IP55	B	-25°C~+60°C	0.8KG	E1

Motor Type	Speed Control	Protection Type	Insulation Class	Operating Temperature	Weight	Wiring Mode
EC BRUSHLESS EXTERNAL ROTOR MOTOR	0-10VDC/PWM	IP55	B	-25°C~+60°C	1.05KG	E1

Forward Curved Centrifugal Fans

Forward Curved Centrifugal Fans

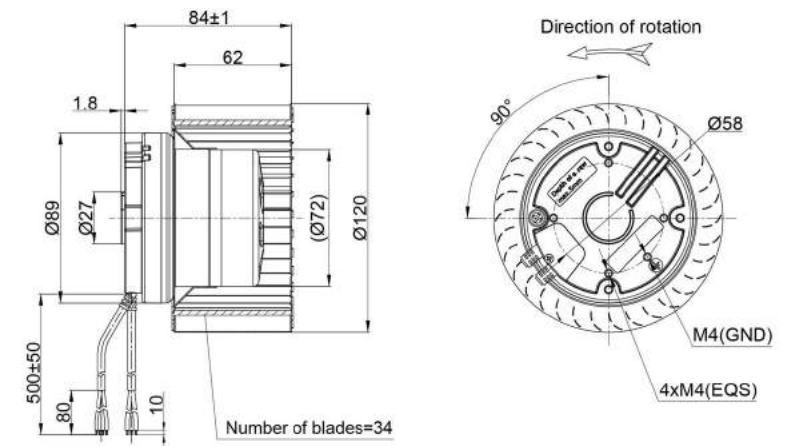
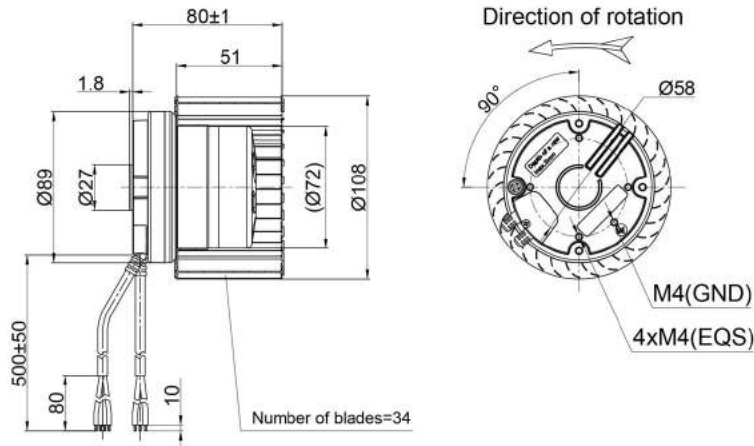

Model	Motor	Bearing System	Rated Voltage	Frequency	Rated Current	Rated Power	Rated Speed	Air Flow	Air Pressure	Sound Level
Part No.	Type	B/S	VAC	Hz	A	W	RPM	M ³ /H	Pa	dB(A)
PF3N108B2E-RZ0	BE72EC	BALL	230	50/60	0.3	38	3400	330	300	57

Model	Motor	Bearing System	Rated Voltage	Frequency	Rated Current	Rated Power	Rated Speed	Air Flow	Air Pressure	Sound Level
Part No.	Type	B/S	VAC	Hz	A	W	RPM	M ³ /H	Pa	dB(A)
PF3N120B2E-RZ0	BE72EC	BALL	230	50/60	0.7	85	3450	350	400	67

EC Centrifugal Fan Forward Curved Ø133x70mm

EC Centrifugal Fan Forward Curved Ø140x86mm

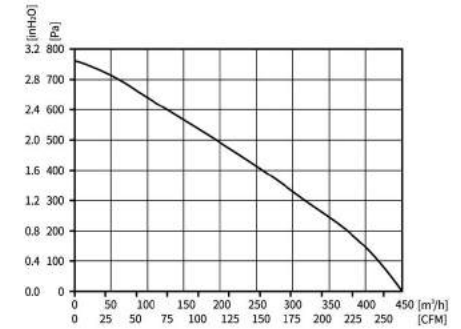
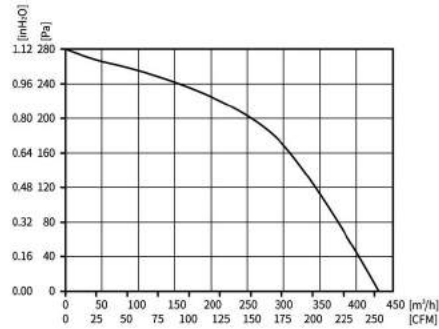

Motor Type	Speed Control	Protection Type	Insulation Class	Operating Temperature	Weight	Wiring Mode
EC BRUSHLESS EXTERNAL ROTOR MOTOR	0-10VDC/PWM	IP55	B	-25°C~+60°C	1.35KG	E1

Motor Type	Speed Control	Protection Type	Insulation Class	Operating Temperature	Weight	Wiring Mode
EC BRUSHLESS EXTERNAL ROTOR MOTOR	0-10VDC/PWM	IP55	B	-25°C~+60°C	1.0KG	E1

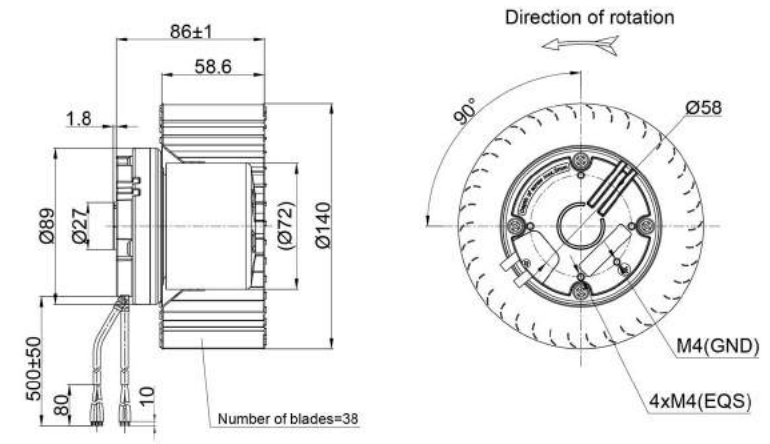
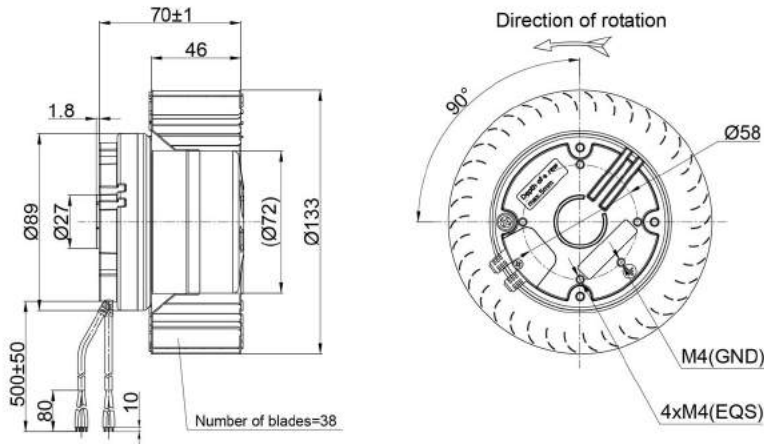

Model	Motor	Bearing System	Rated Voltage	Frequency	Rated Current	Rated Power	Rated Speed	Air Flow	Air Pressure	Sound Level
Part No.	Type	B/S	VAC	Hz	A	W	RPM	M ³ /H	Pa	dB(A)
PF3N133B2E-R20	BE72EC	BALL	230	50/60	0.65	85	3200	430	280	63

Model	Motor	Bearing System	Rated Voltage	Frequency	Rated Current	Rated Power	Rated Speed	Air Flow	Air Pressure	Sound Level
Part No.	Type	B/S	VAC	Hz	A	W	RPM	M ³ /H	Pa	dB(A)
PF3N140B2E-R20	BE72EC	BALL	230	50/60	0.7	85	1900	450	760	72

EC Centrifugal Fan Forward Curved Ø140x72mm

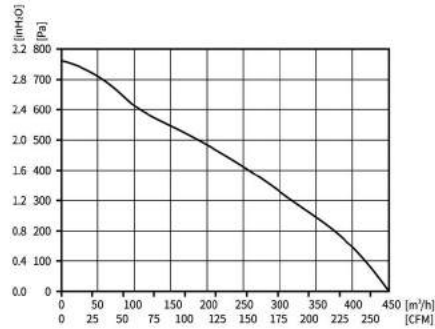

Motor Type EC BRUSHLESS EXTERNAL ROTOR MOTOR	Speed Control 0-10VDC/PWM	Protection Type IP55	Insulation Class B	Operating Temperature -25°C~+60°C	Weight 1.2KG	Wiring Mode E1
---	------------------------------	-------------------------	-----------------------	--------------------------------------	-----------------	-------------------

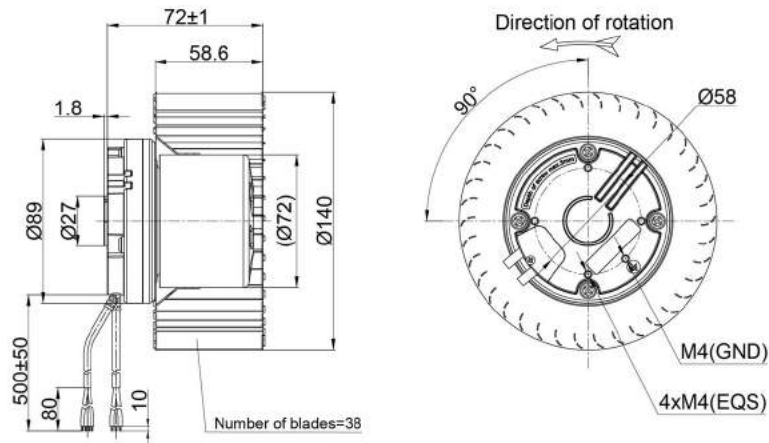

Model	Motor	Bearing System	Rated Voltage	Frequency	Rated Current	Rated Power	Rated Speed	Air Flow	Air Pressure	Sound Level
Part No.	Type	B/S	VAC	Hz	A	W	RPM	M ³ /H	Pa	dB(A)
PF3N140B2E-RP0	BE72EC	BALL	230	50/60	0.7	85	1900	450	760	72

EC Centrifugal Fan Forward Curved Ø140x80mm

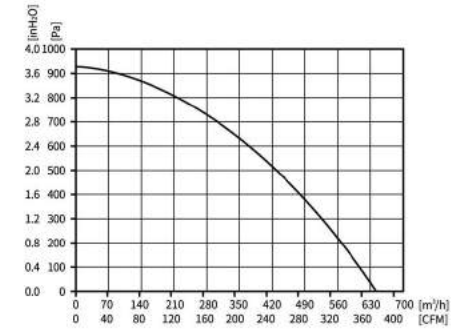

Motor Type EC BRUSHLESS EXTERNAL ROTOR MOTOR	Speed Control 0-10VDC/PWM	Protection Type IP55	Insulation Class B	Operating Temperature -25°C~+60°C	Weight 1.45KG	Wiring Mode E1
---	------------------------------	-------------------------	-----------------------	--------------------------------------	------------------	-------------------

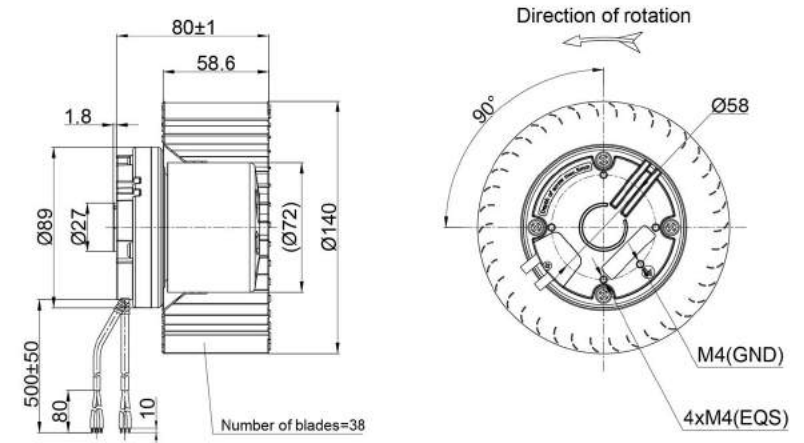

Model	Motor	Bearing System	Rated Voltage	Frequency	Rated Current	Rated Power	Rated Speed	Air Flow	Air Pressure	Sound Level
Part No.	Type	B/S	VAC	Hz	A	W	RPM	M ³ /H	Pa	dB(A)
PF3N140B2E-SZ0	BE72EC	BALL	230	50/60	0.85	115	2000	640	920	67

EC Centrifugal Fan Forward Curved Ø146x85mm

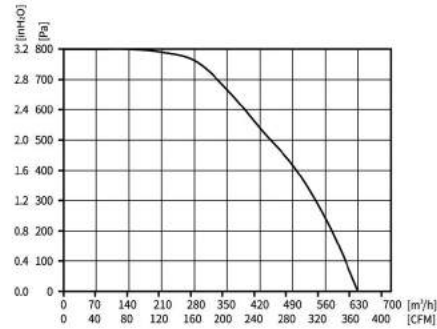

Motor Type	Speed Control	Protection Type	Insulation Class	Operating Temperature	Weight	Wiring Mode
EC BRUSHLESS EXTERNAL ROTOR MOTOR	0-10VDC/PWM	IP55	B	-25°C~+60°C	1.25KG	E1

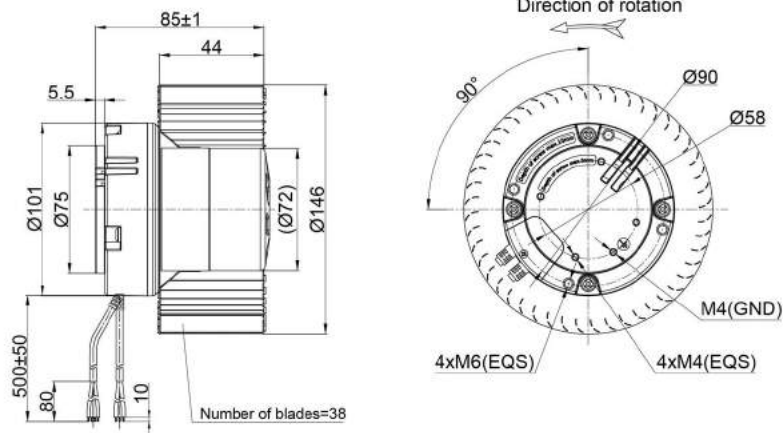

Model	Motor	Bearing System	Rated Voltage	Frequency	Rated Current	Rated Power	Rated Speed	Air Flow	Air Pressure	Sound Level
Part No.	Type	B/S	VAC	Hz	A	W	RPM	M ³ /H	Pa	dB(A)
PF3N146B2E-TZ0	BE72EC	BALL	230	50/60	0.6	170	2600	630	800	73

EC Centrifugal Fan Forward Curved Ø160x108mm

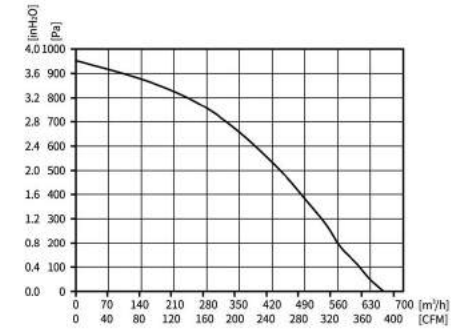

Motor Type	Speed Control	Protection Type	Insulation Class	Operating Temperature	Weight	Wiring Mode
EC BRUSHLESS EXTERNAL ROTOR MOTOR	0-10VDC/PWM	IP55	B	-25°C~+60°C	1.35KG	E1

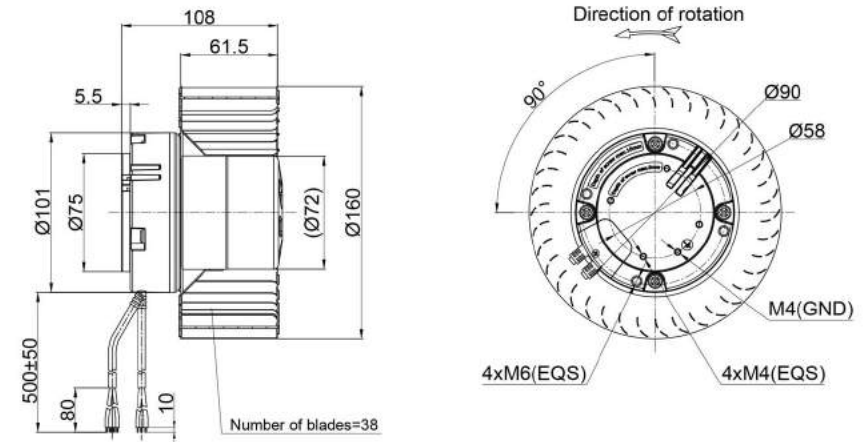

Model	Motor	Bearing System	Rated Voltage	Frequency	Rated Current	Rated Power	Rated Speed	Air Flow	Air Pressure	Sound Level
Part No.	Type	B/S	VAC	Hz	A	W	RPM	M ³ /H	Pa	dB(A)
PF3N160B2E-TP0	BE72EC	BALL	230	50/60	1.2	170	2000	660	950	67

EC Centrifugal Fan Forward Curved Ø160x108mm

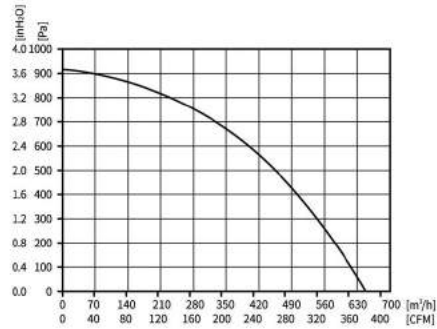

Motor Type	Speed Control	Protection Type	Insulation Class	Operating Temperature	Weight	Wiring Mode
EC BRUSHLESS EXTERNAL ROTOR MOTOR	0-10VDC/PWM	IP55	B	-25°C~+60°C	1.5KG	E1

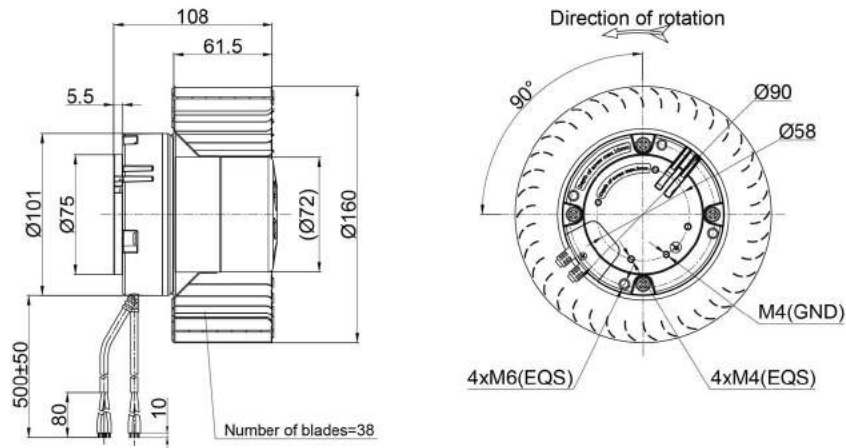

Model	Motor	Bearing System	Rated Voltage	Frequency	Rated Current	Rated Power	Rated Speed	Air Flow	Air Pressure	Sound Level
Part No.	Type	B/S	VAC	Hz	A	W	RPM	M ³ /H	Pa	dB(A)
PF3N160B2E-TZ0	BE72EC	BALL	230	50/60	1.1	155	1900	640	910	68

EC Centrifugal Fan Forward Curved Ø160x108mm

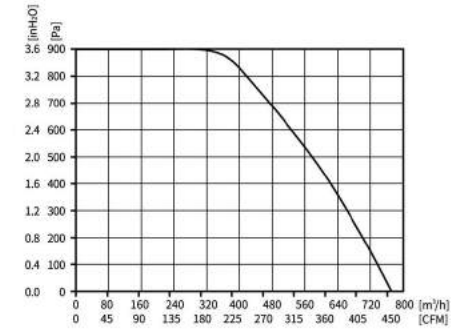

Motor Type	Speed Control	Protection Type	Insulation Class	Operating Temperature	Weight	Wiring Mode
EC BRUSHLESS EXTERNAL ROTOR MOTOR	0-10VDC/PWM	IP55	B	-25°C~+60°C	1.5KG	E2

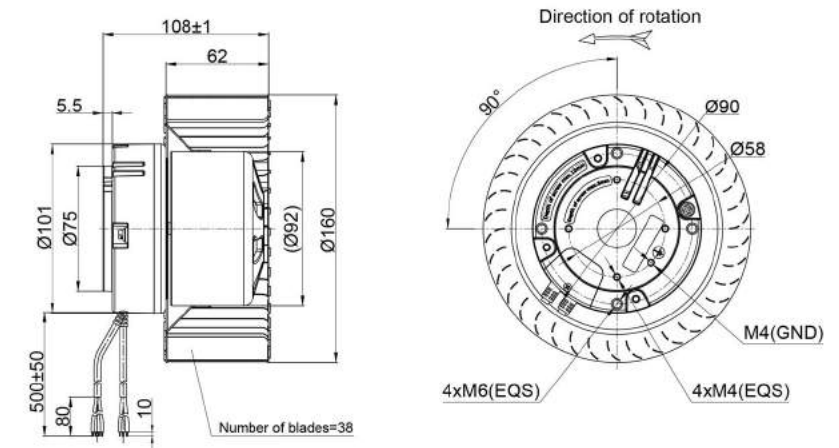

Model	Motor	Bearing System	Rated Voltage	Frequency	Rated Current	Rated Power	Rated Speed	Air Flow	Air Pressure	Sound Level
Part No.	Type	B/S	VAC	Hz	A	W	RPM	M ³ /H	Pa	dB(A)
PF3N160B2E-MP0	BE92EC	BALL	230	50/60	1.55	220	2300	770	900	71

EC Centrifugal Fan Forward Curved Ø160x108mm

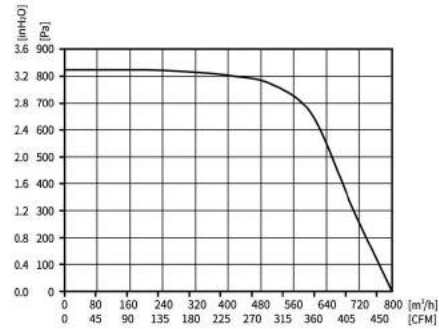

Motor Type	Speed Control	Protection Type	Insulation Class	Operating Temperature	Weight	Wiring Mode
EC BRUSHLESS EXTERNAL ROTOR MOTOR	0-10VDC/PWM	IP55	B	-25°C~+60°C	1.7KG	E2

EC Centrifugal Fan Forward Curved Ø180x126mm

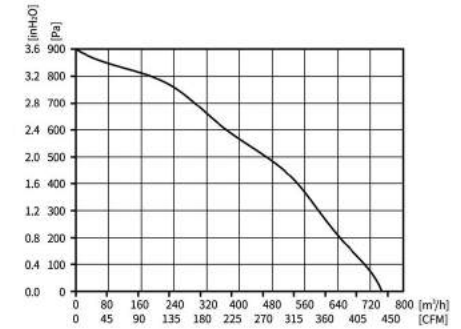

Motor Type	Speed Control	Protection Type	Insulation Class	Operating Temperature	Weight	Wiring Mode
EC BRUSHLESS EXTERNAL ROTOR MOTOR	0-10VDC/PWM	IP55	B	-25°C~+60°C	1.65KG	E1

Forward Curved Centrifugal Fans

Forward Curved Centrifugal Fans

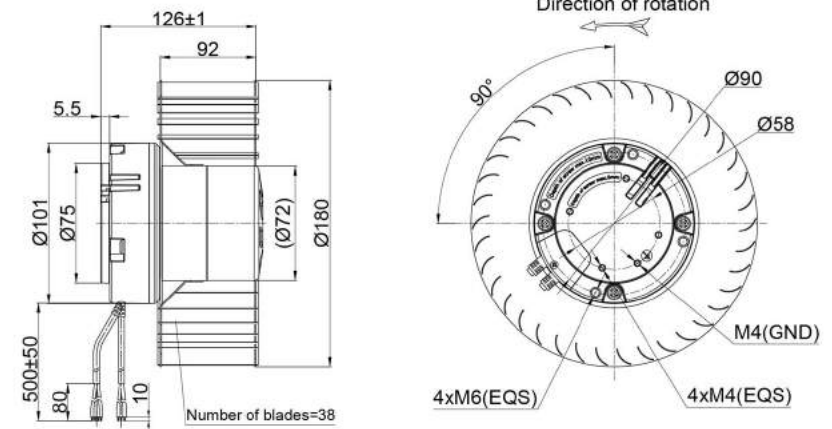
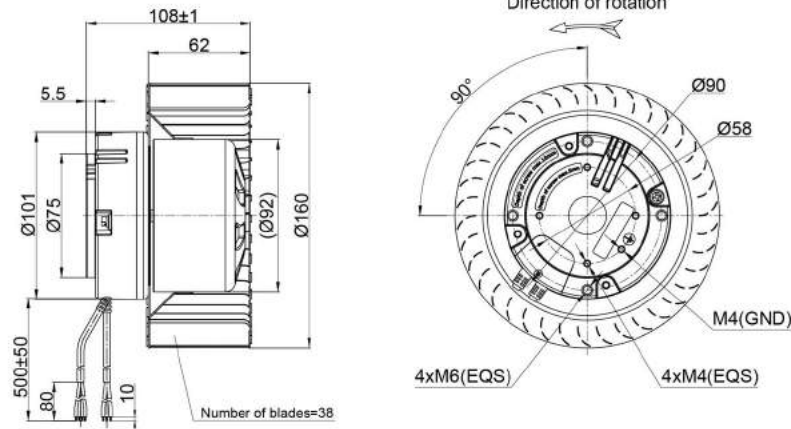

Model	Motor	Bearing System	Rated Voltage	Rated Frequency	Rated Current	Rated Power	Rated Speed	Air Flow	Air Pressure	Sound Level
Part No.	Type	B/S	VAC	Hz	A	W	RPM	M ³ /H	Pa	dB(A)
PF3N160B2E-MZ0	BE92EC	BALL	230	50/60	1.6	220	2300	800	820	73

Model	Motor	Bearing System	Rated Voltage	Rated Frequency	Rated Current	Rated Power	Rated Speed	Air Flow	Air Pressure	Sound Level
Part No.	Type	B/S	VAC	Hz	A	W	RPM	M ³ /H	Pa	dB(A)
PF3N180B2E-TZ0	BE72EC	BALL	230	50/60	1.2	170	1550	750	900	66

EC Centrifugal Fan Forward Curved Ø180x126mm

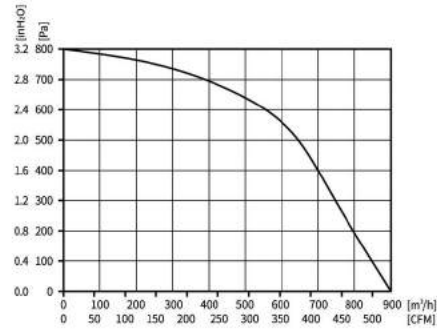

Motor Type	Speed Control	Protection Type	Insulation Class	Operating Temperature	Weight	Wiring Mode
EC BRUSHLESS EXTERNAL ROTOR MOTOR	0-10VDC/PWM	IP55	B	-25°C~+60°C	1.8KG	E2

EC Centrifugal Fan Forward Curved Ø200x140mm

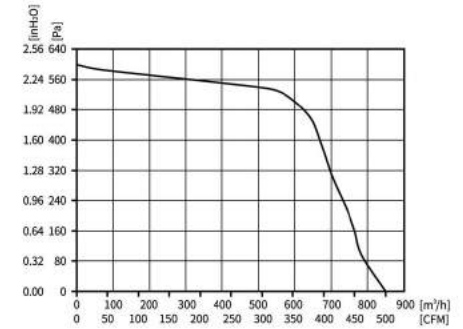

Motor Type	Speed Control	Protection Type	Insulation Class	Operating Temperature	Weight	Wiring Mode
EC BRUSHLESS EXTERNAL ROTOR MOTOR	0-10VDC/PWM	IP55	B	-25°C~+60°C	2.7KG	E2

Forward Curved Centrifugal Fans

Forward Curved Centrifugal Fans

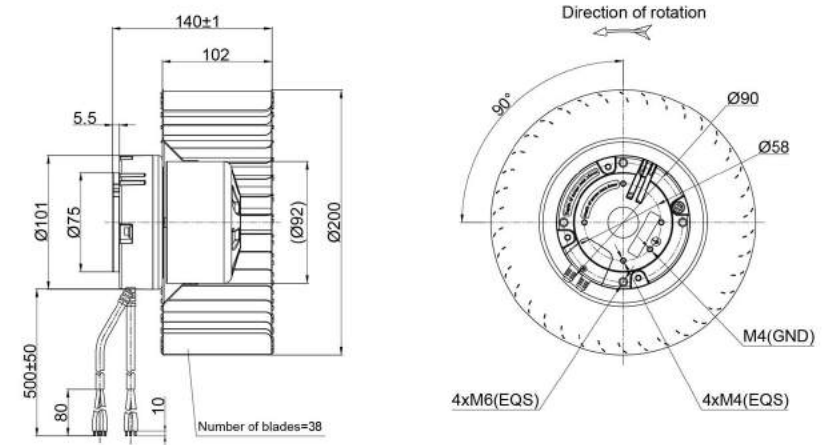
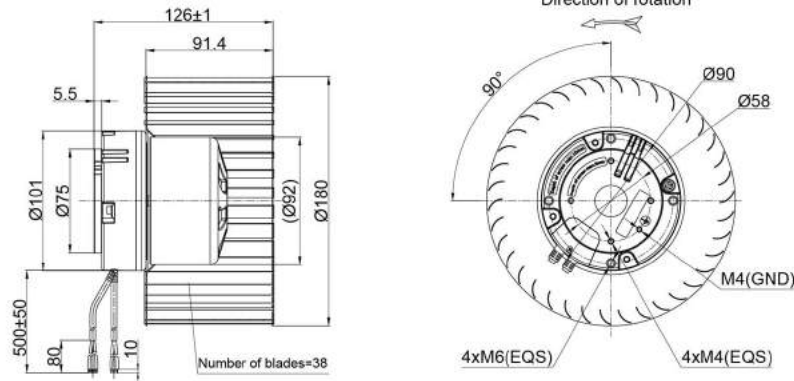

Model	Motor	Bearing System	Rated Voltage	Frequency	Rated Current	Rated Power	Rated Speed	Air Flow	Air Pressure	Sound Level
Part No.	Type	B/S	VAC	Hz	A	W	RPM	M ³ /H	Pa	dB(A)
PF3N180B2E-MZ0	BE92EC	BALL	230	50/60	1.55	220	1800	900	800	68

Model	Motor	Bearing System	Rated Voltage	Frequency	Rated Current	Rated Power	Rated Speed	Air Flow	Air Pressure	Sound Level
Part No.	Type	B/S	VAC	Hz	A	W	RPM	M ³ /H	Pa	dB(A)
PF3N200B2E-MZ0	BE92EC	BALL	230	50/60	1.7	220	2200	850	600	74

EC Blower Single Inlet Ø120mm

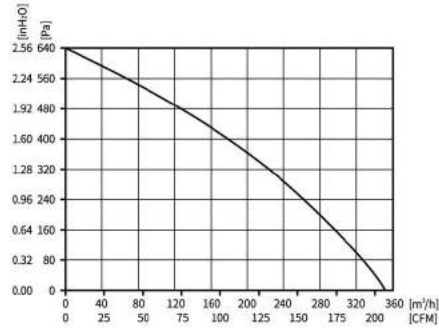

Motor Type EC BRUSHLESS EXTERNAL ROTOR MOTOR	Speed Control 0-10VDC/PWM	Protection Type IP55	Insulation Class B	Operating Temperature -25°C ~ +60°C	Weight 1.55KG	Wiring Mode E1
---	------------------------------	-------------------------	-----------------------	--	------------------	-------------------

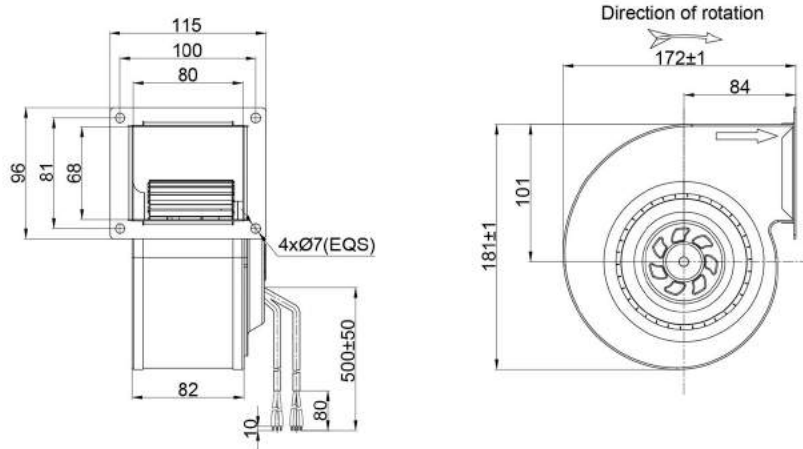

Model	Motor	Bearing System	Rated Voltage	Frequency	Rated Current	Rated Power	Rated Speed	Air Flow	Air Pressure	Sound Level
Part No.	Type	B/S	VAC	Hz	A	W	RPM	M³/H	Pa	dB(A)
PS3N120B2E-RZ0	BE72EC	BALL	230	50/60	0.55	72	2500	350	640	61

EC Blower Single Inlet Ø140mm

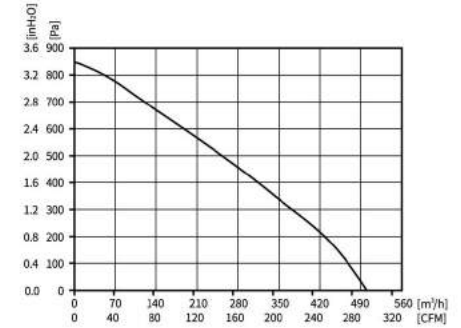

Motor Type EC BRUSHLESS EXTERNAL ROTOR MOTOR	Speed Control 0-10VDC/PWM	Protection Type IP55	Insulation Class B	Operating Temperature -25°C ~ +60°C	Weight 2.15KG	Wiring Mode E1
---	------------------------------	-------------------------	-----------------------	--	------------------	-------------------

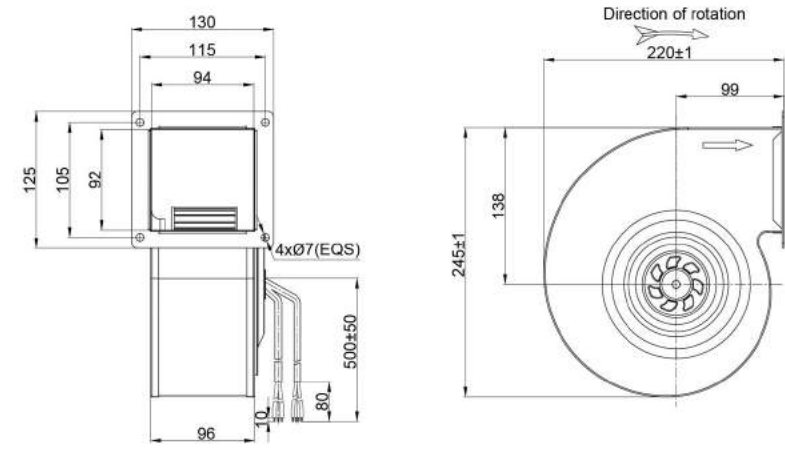

Model	Motor	Bearing System	Rated Voltage	Frequency	Rated Current	Rated Power	Rated Speed	Air Flow	Air Pressure	Sound Level
Part No.	Type	B/S	VAC	Hz	A	W	RPM	M³/H	Pa	dB(A)
PS3N140B2E-RP0	BE72EC	BALL	230	50/60	0.61	85	1800	500	850	66

Single Inlet Blowers

Single Inlet Blowers

EC Blower Single Inlet Ø140mm

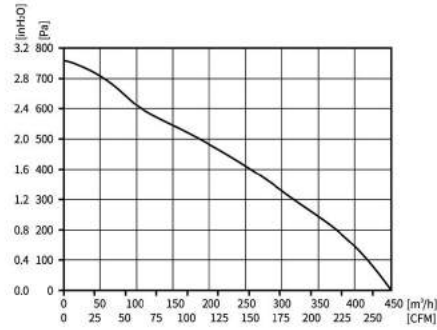

Motor Type EC BRUSHLESS EXTERNAL ROTOR MOTOR	Speed Control 0-10VDC/PWM	Protection Type IP55	Insulation Class B	Operating Temperature -25°C ~ +60°C	Weight 2.4KG	Wiring Mode E1
---	------------------------------	-------------------------	-----------------------	--	-----------------	-------------------

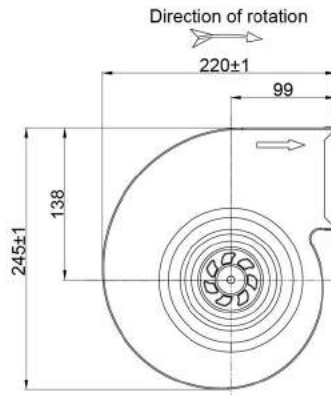
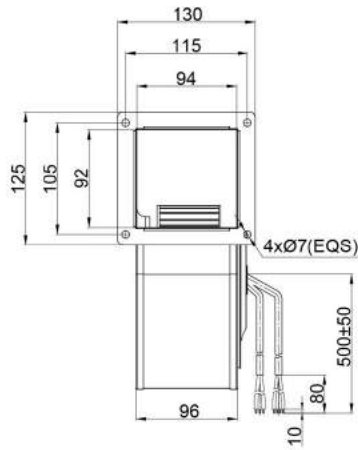

Model	Motor	Bearing System	Rated Voltage	Frequency	Rated Current	Rated Power	Rated Speed	Air Flow	Air Pressure	Sound Level
Part No.	Type	B/S	VAC	Hz	A	W	RPM	M ³ /H	Pa	dB(A)
PS3N140B2E-RZ0	BE72EC	BALL	230	50/60	0.6	85	1700	450	750	65

EC Blower Single Inlet Ø140mm

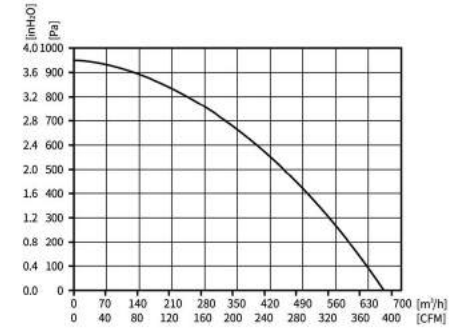

Motor Type EC BRUSHLESS EXTERNAL ROTOR MOTOR	Speed Control 0-10VDC/PWM	Protection Type IP55	Insulation Class B	Operating Temperature -25°C ~ +60°C	Weight 2.8KG	Wiring Mode E1
---	------------------------------	-------------------------	-----------------------	--	-----------------	-------------------

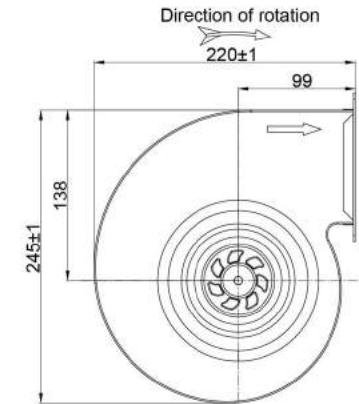
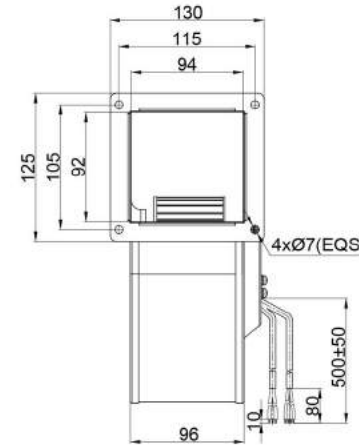

Model	Motor	Bearing System	Rated Voltage	Frequency	Rated Current	Rated Power	Rated Speed	Air Flow	Air Pressure	Sound Level
Part No.	Type	B/S	VAC	Hz	A	W	RPM	M ³ /H	Pa	dB(A)
PS3N140B2E-TP0	BE72EC	BALL	230	50/60	0.85	115	2000	650	950	67

EC Blower Single Inlet Ø140mm

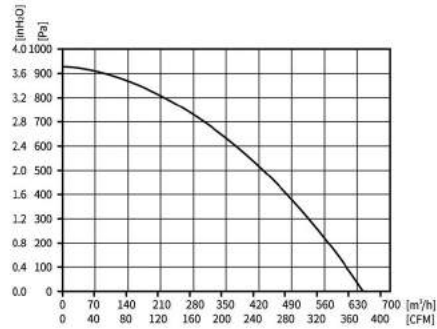

Motor Type EC BRUSHLESS EXTERNAL ROTOR MOTOR	Speed Control 0-10VDC/PWM	Protection Type IP55	Insulation Class B	Operating Temperature -25°C ~ +60°C	Weight 2.8KG	Wiring Mode E1
---	------------------------------	-------------------------	-----------------------	--	-----------------	-------------------

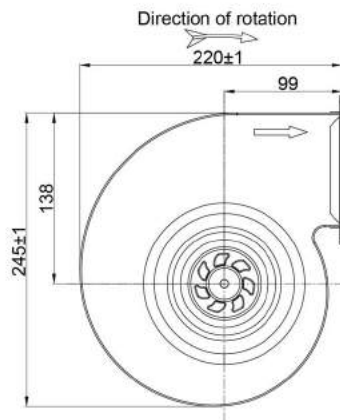
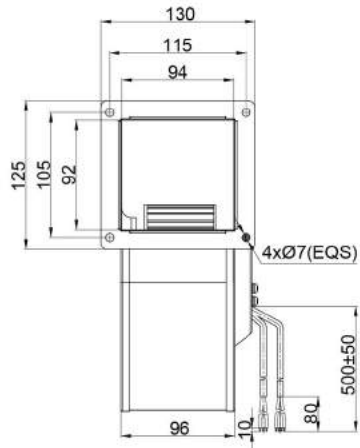

Model	Motor	Bearing System	Rated Voltage	Frequency	Rated Current	Rated Power	Rated Speed	Air Flow	Air Pressure	Sound Level
Part No.	Type	B/S	VAC	Hz	A	W	RPM	M³/H	Pa	dB(A)
PS3N140B2E-T20	BE72EC	BALL	230	50/60	0.85	115	2000	640	920	67

EC Blower Single Inlet Ø160mm

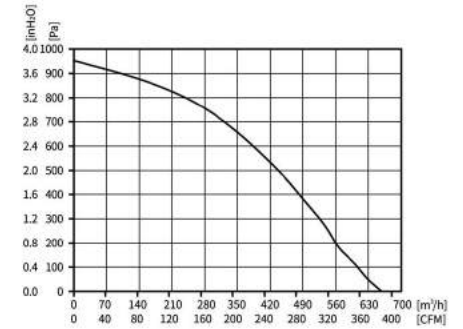

Motor Type EC BRUSHLESS EXTERNAL ROTOR MOTOR	Speed Control 0-10VDC/PWM	Protection Type IP55	Insulation Class B	Operating Temperature -25°C ~ +60°C	Weight 2.4KG	Wiring Mode E1
---	------------------------------	-------------------------	-----------------------	--	-----------------	-------------------

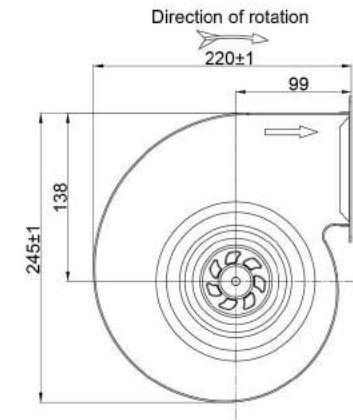
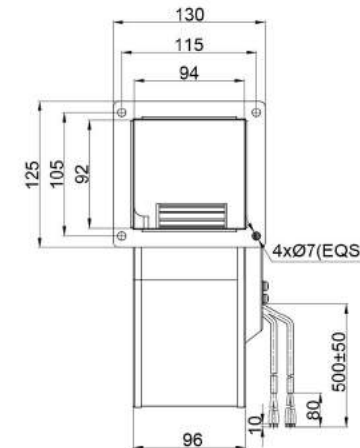

Model	Motor	Bearing System	Rated Voltage	Frequency	Rated Current	Rated Power	Rated Speed	Air Flow	Air Pressure	Sound Level
Part No.	Type	B/S	VAC	Hz	A	W	RPM	M³/H	Pa	dB(A)
PS3N160B2E-TP0	BE72EC	BALL	230	50/60	1.2	170	2000	660	950	67

EC Blower Single Inlet Ø160mm

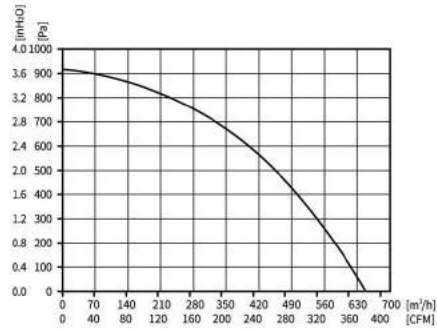

Motor Type EC BRUSHLESS EXTERNAL ROTOR MOTOR	Speed Control 0-10VDC/PWM	Protection Type IP55	Insulation Class B	Operating Temperature -25°C~+60°C	Weight 2.8KG	Wiring Mode E1
---	------------------------------	-------------------------	-----------------------	--------------------------------------	-----------------	-------------------

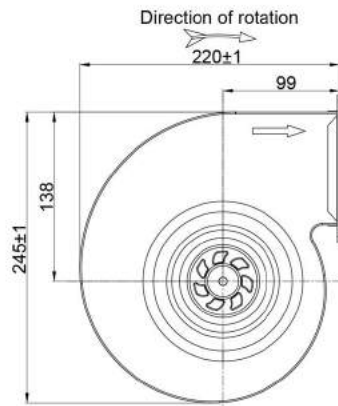
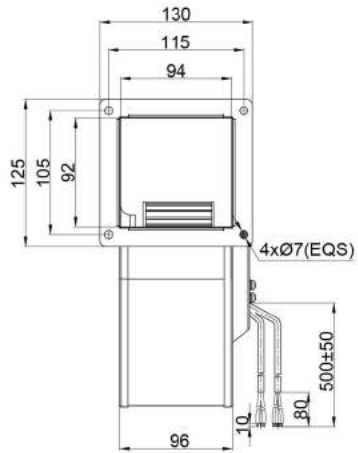

Model	Motor	Bearing System	Rated Voltage	Frequency	Rated Current	Rated Power	Rated Speed	Air Flow	Air Pressure	Sound Level
Part No.	Type	B/S	VAC	Hz	A	W	RPM	M³/H	Pa	dB(A)
PS3N160B2E-T20	BE72EC	BALL	230	50/60	1.1	155	1900	640	910	68

EC Blower Single Inlet Ø160mm

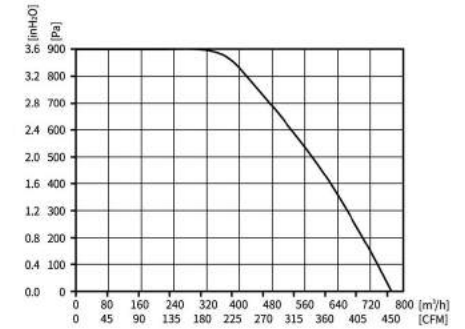

Motor Type EC BRUSHLESS EXTERNAL ROTOR MOTOR	Speed Control 0-10VDC/PWM	Protection Type IP55	Insulation Class B	Operating Temperature -25°C~+60°C	Weight 2.4KG	Wiring Mode E2
---	------------------------------	-------------------------	-----------------------	--------------------------------------	-----------------	-------------------

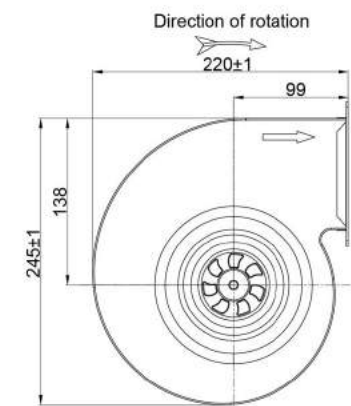
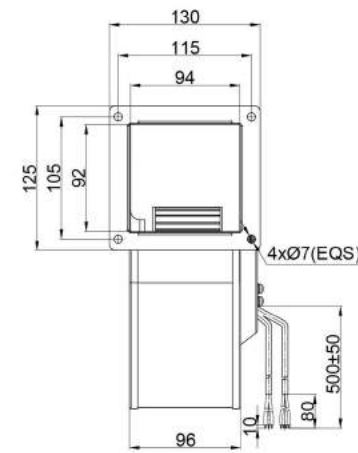

Model	Motor	Bearing System	Rated Voltage	Frequency	Rated Current	Rated Power	Rated Speed	Air Flow	Air Pressure	Sound Level
Part No.	Type	B/S	VAC	Hz	A	W	RPM	M³/H	Pa	dB(A)
PS3N160B2E-MP0	BE92EC	BALL	230	50/60	1.55	220	2300	770	900	71

EC Blower Single Inlet Ø160mm

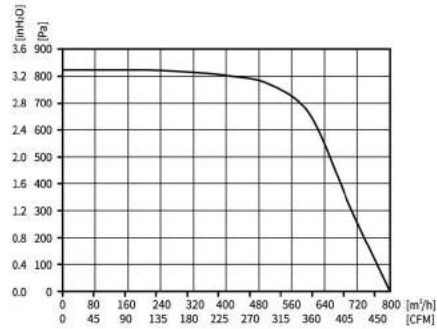

Motor Type EC BRUSHLESS EXTERNAL ROTOR MOTOR	Speed Control 0-10VDC/PWM	Protection Type IP55	Insulation Class B	Operating Temperature -25°C~+60°C	Weight 2.8KG	Wiring Mode E2
---	------------------------------	-------------------------	-----------------------	--------------------------------------	-----------------	-------------------

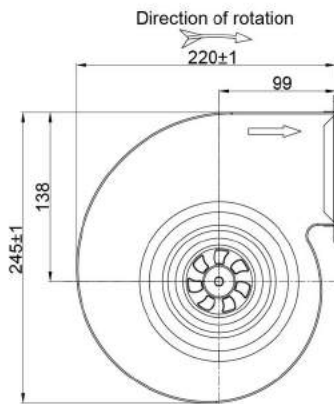
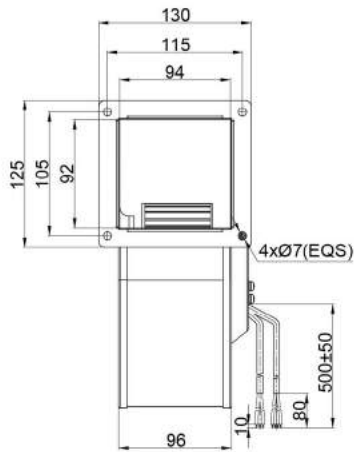

Model	Motor	Bearing System	Rated Voltage	Frequency	Rated Current	Rated Power	Rated Speed	Air Flow	Air Pressure	Sound Level
Part No.	Type	B/S	VAC	Hz	A	W	RPM	M³/H	Pa	dB(A)
PS3N160B2E-MZO	BE92EC	BALL	230	50/60	1.6	220	2300	800	820	73

EC Blower Single Inlet Ø180mm

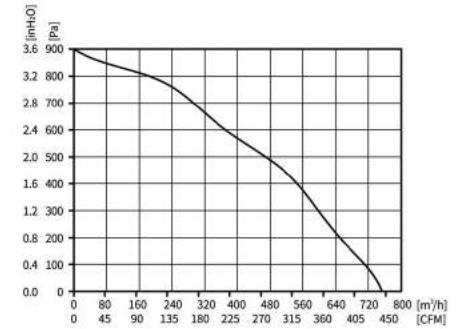

Motor Type EC BRUSHLESS EXTERNAL ROTOR MOTOR	Speed Control 0-10VDC/PWM	Protection Type IP55	Insulation Class B	Operating Temperature -25°C~+60°C	Weight 3.7KG	Wiring Mode E1
---	------------------------------	-------------------------	-----------------------	--------------------------------------	-----------------	-------------------

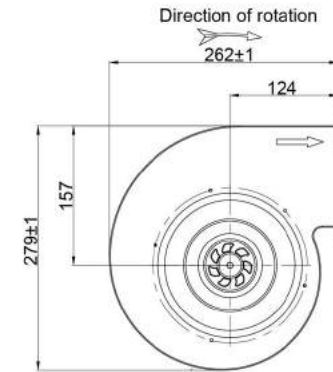
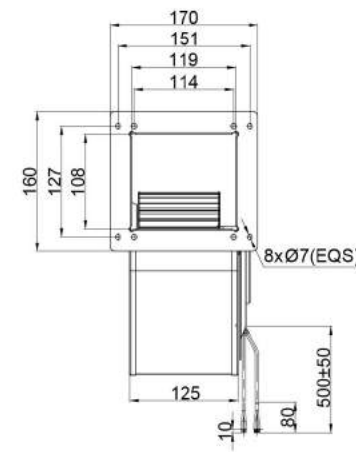

Model	Motor	Bearing System	Rated Voltage	Frequency	Rated Current	Rated Power	Rated Speed	Air Flow	Air Pressure	Sound Level
Part No.	Type	B/S	VAC	Hz	A	W	RPM	M³/H	Pa	dB(A)
PS3N180B2E-TZO	BE72EC	BALL	230	50/60	1.2	170	1550	750	900	66

EC Blower Single Inlet Ø180mm

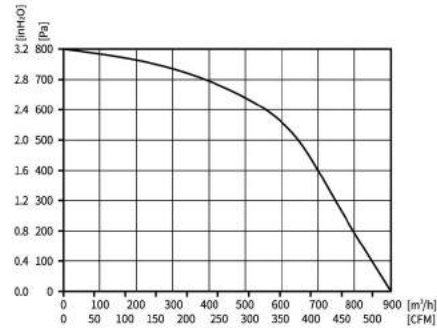

Motor Type EC BRUSHLESS EXTERNAL ROTOR MOTOR	Speed Control 0-10VDC/PWM	Protection Type IP55	Insulation Class B	Operating Temperature -25°C~+60°C	Weight 3.9KG	Wiring Mode E2
---	------------------------------	-------------------------	-----------------------	--------------------------------------	-----------------	-------------------

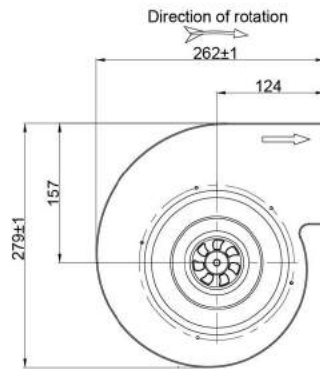
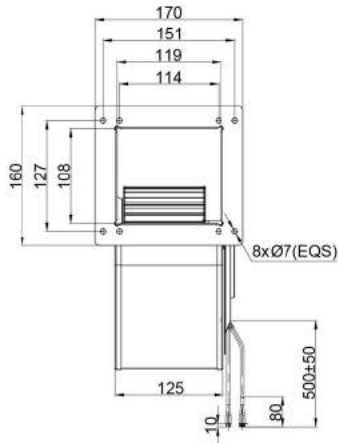

Model Part No.	Motor Type	Bearing System B/S	Rated Voltage VAC	Frequency Hz	Rated Current A	Rated Power W	Rated Speed RPM	Air Flow M³/H	Air Pressure Pa	Sound Level dB(A)
PS3N180B2E-MZO	BE92EC	BALL	230	50/60	1.55	220	1800	900	800	68

EC Blower Single Inlet Ø180mm

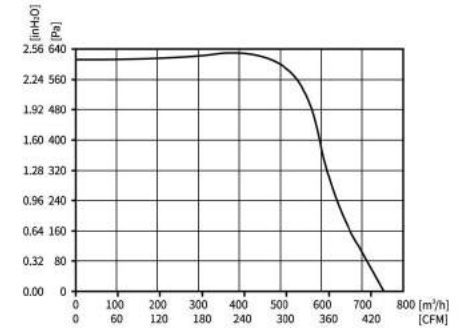

Motor Type EC BRUSHLESS EXTERNAL ROTOR MOTOR	Speed Control 0-10VDC/PWM	Protection Type IP55	Insulation Class B	Operating Temperature -25°C~+60°C	Weight 3.53KG	Wiring Mode E2
---	------------------------------	-------------------------	-----------------------	--------------------------------------	------------------	-------------------

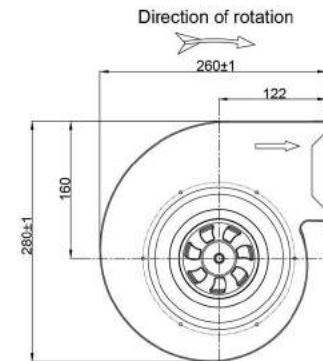
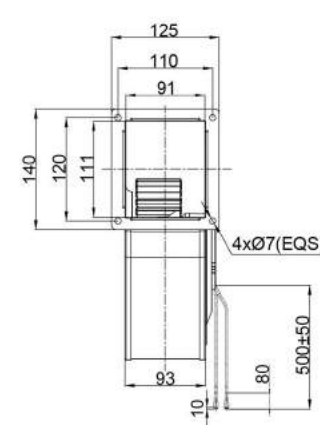

Model Part No.	Motor Type	Bearing System B/S	Rated Voltage VAC	Frequency Hz	Rated Current A	Rated Power W	Rated Speed RPM	Air Flow M³/H	Air Pressure Pa	Sound Level dB(A)
PS3N180B2E-MZ1	BE92EC	BALL	230	50/60	1.5	220	2100	752	610	72

Single Inlet Blowers

Single Inlet Blowers

EC Blower Single Inlet Ø200mm

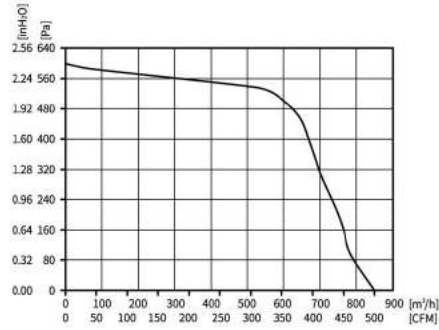

Motor Type EC BRUSHLESS EXTERNAL ROTOR MOTOR	Speed Control 0-10VDC/PWM	Protection Type IP55	Insulation Class B	Operating Temperature -25°C ~ +60°C	Weight 4.3KG	Wiring Mode E2
---	------------------------------	-------------------------	-----------------------	--	-----------------	-------------------

EC Blower Dual Inlet Ø133mm

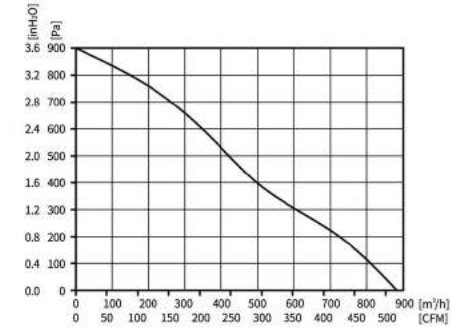

Motor Type EC BRUSHLESS EXTERNAL ROTOR MOTOR	Speed Control 0-10VDC/PWM	Protection Type IP55	Insulation Class B	Operating Temperature -25°C ~ +60°C	Weight 3.2KG	Wiring Mode E1
---	------------------------------	-------------------------	-----------------------	--	-----------------	-------------------

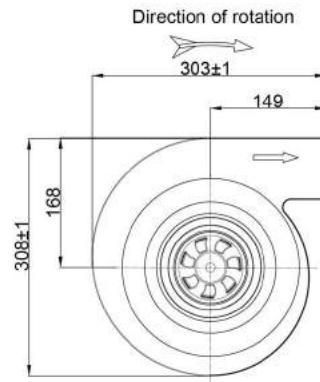
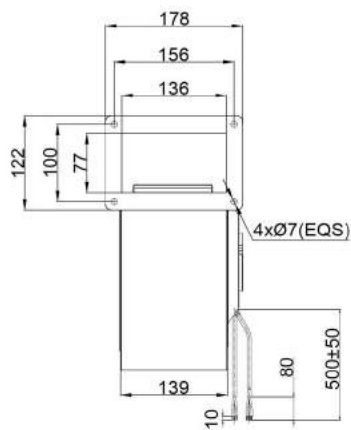

Model	Motor	Bearing System	Rated Voltage	Frequency	Rated Current	Rated Power	Rated Speed	Air Flow	Air Pressure	Sound Level
Part No.	Type	B/S	VAC	Hz	A	W	RPM	M³/H	Pa	dB(A)
PS3N200B2E-MZO	BE92EC	BALL	230	50/60	1.7	220	2200	850	600	74

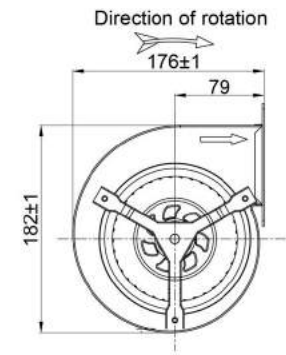
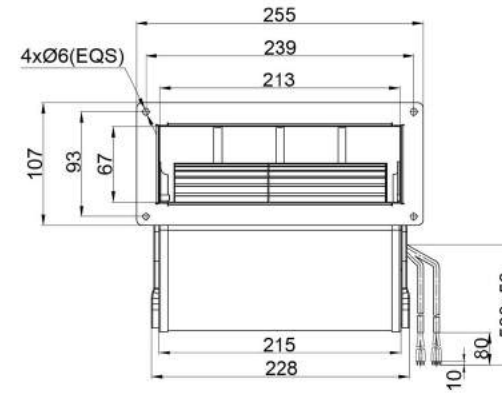

Model	Motor	Bearing System	Rated Voltage	Frequency	Rated Current	Rated Power	Rated Speed	Air Flow	Air Pressure	Sound Level
Part No.	Type	B/S	VAC	Hz	A	W	RPM	M³/H	Pa	dB(A)
PD3N133B2E-TZO	BE72EC	BALL	230	50/60	1.0	140	1900	880	900	67

Single Inlet Blowers

Dual Inlet Blowers

EC Blower Dual Inlet Ø146mm

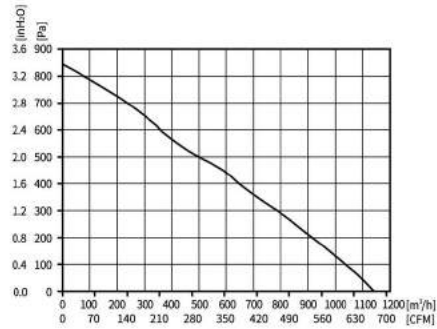

Motor Type EC BRUSHLESS EXTERNAL ROTOR MOTOR	Speed Control 0-10VDC/PWM	Protection Type IP55	Insulation Class B	Operating Temperature -25°C ~ +60°C	Weight 4.1KG	Wiring Mode E1
---	------------------------------	-------------------------	-----------------------	--	-----------------	-------------------

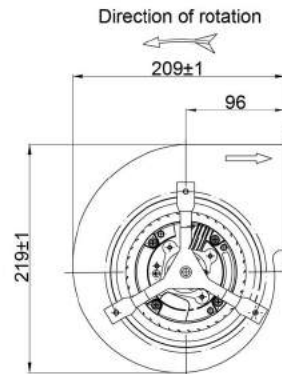
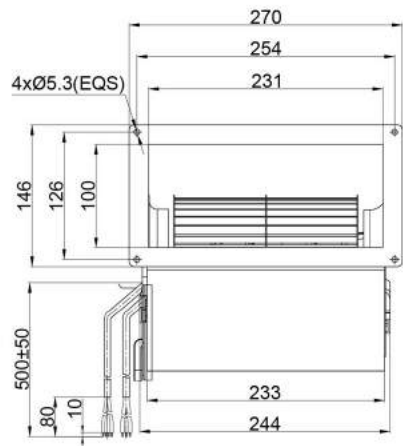

Model	Motor	Bearing System	Rated Voltage	Frequency	Rated Current	Rated Power	Rated Speed	Air Flow	Air Pressure	Sound Level
Part No.	Type	B/S	VAC	Hz	A	W	RPM	M³/H	Pa	dB(A)
PD3N146B2E-TZ0	BE72EC	BALL	230	50/60	1.2	170	1500	1140	845	68

EC Blower Dual Inlet Ø146mm

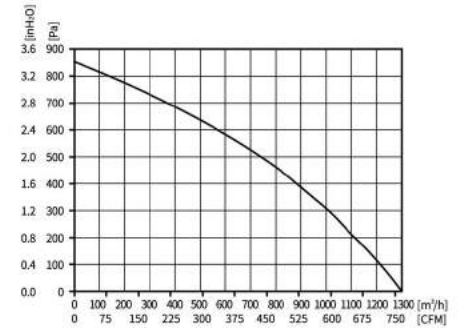

Motor Type EC BRUSHLESS EXTERNAL ROTOR MOTOR	Speed Control 0-10VDC/PWM	Protection Type IP55	Insulation Class B	Operating Temperature -25°C ~ +60°C	Weight 4.4KG	Wiring Mode E2
---	------------------------------	-------------------------	-----------------------	--	-----------------	-------------------

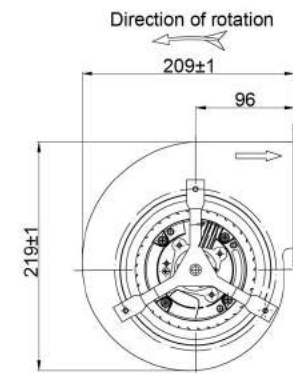
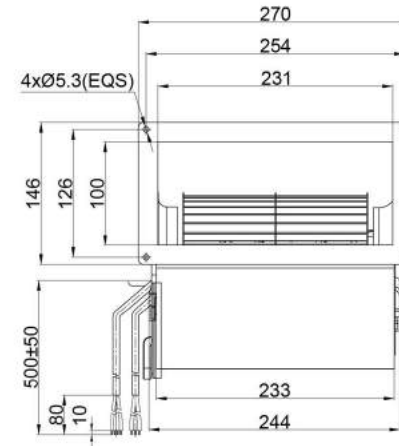

Model	Motor	Bearing System	Rated Voltage	Frequency	Rated Current	Rated Power	Rated Speed	Air Flow	Air Pressure	Sound Level
Part No.	Type	B/S	VAC	Hz	A	W	RPM	M³/H	Pa	dB(A)
PD3N146B2E-MZ0	BE92EC	BALL	230	50/60	1.55	220	1850	1300	850	72

Dual Inlet Blowers

Dual Inlet Blowers

EC Blower Dual Inlet Ø146mm

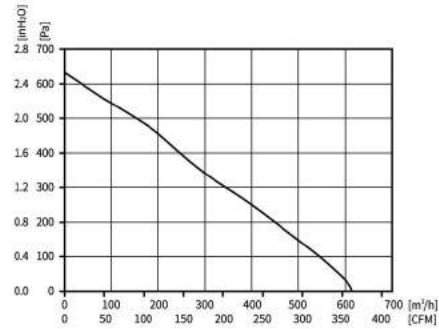

Motor Type EC BRUSHLESS EXTERNAL ROTOR MOTOR	Speed Control 0-10VDC/PWM	Protection Type IP55	Insulation Class B	Operating Temperature -25°C~+60°C	Weight 2.4KG	Wiring Mode E1
---	------------------------------	-------------------------	-----------------------	--------------------------------------	-----------------	-------------------

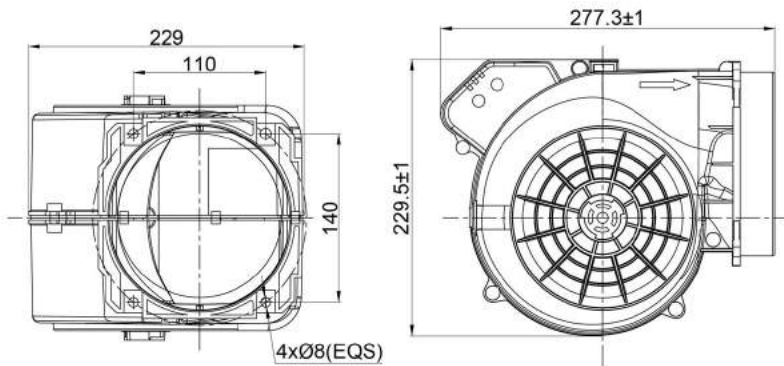

Model Part No.	Motor Type	Bearing System B/S	Rated Voltage VAC	Frequency Hz	Rated Current A	Rated Power W	Rated Speed RPM	Air Flow M³/H	Air Pressure Pa	Sound Level dB(A)
PD3N146B2E-RV0	BE72EC	BALL	230	50/60	0.65	85	1400	610	620	63

EC Blower Dual Inlet Ø146mm

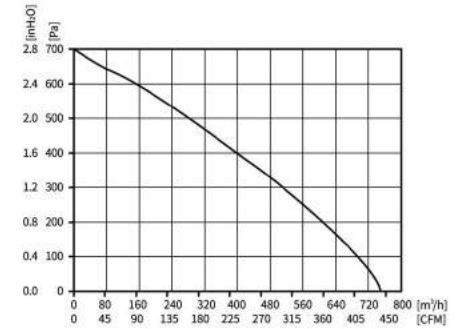

Motor Type EC BRUSHLESS EXTERNAL ROTOR MOTOR	Speed Control 0-10VDC/PWM	Protection Type IP55	Insulation Class B	Operating Temperature -25°C~+60°C	Weight 2.4KG	Wiring Mode E1
---	------------------------------	-------------------------	-----------------------	--------------------------------------	-----------------	-------------------

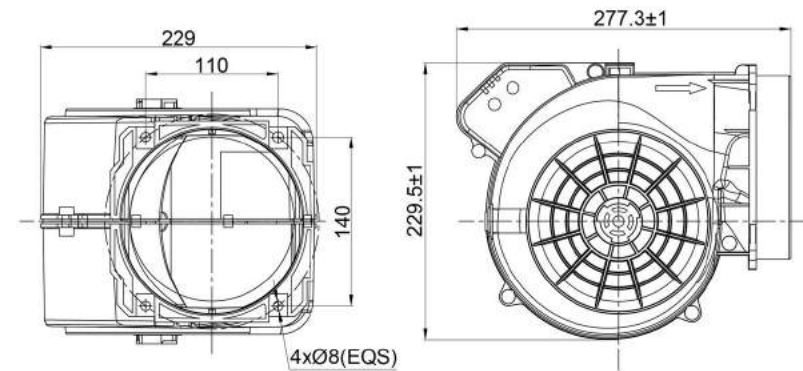

Model Part No.	Motor Type	Bearing System B/S	Rated Voltage VAC	Frequency Hz	Rated Current A	Rated Power W	Rated Speed RPM	Air Flow M³/H	Air Pressure Pa	Sound Level dB(A)
PD3N146B2E-RV1	BE72EC	BALL	230	50/60	1.1	145	1600	750	700	66

EC-AC Motor

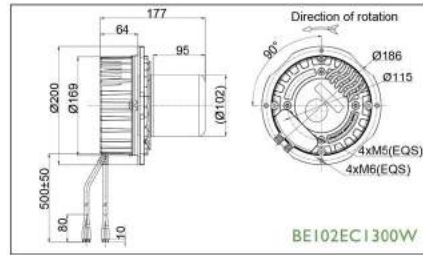
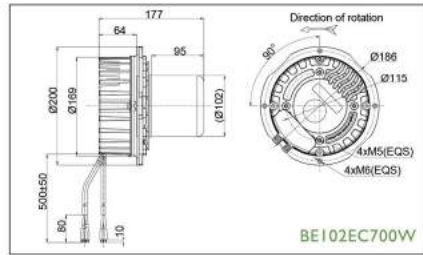
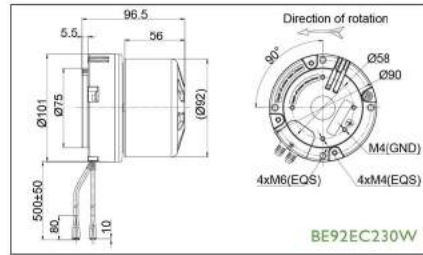
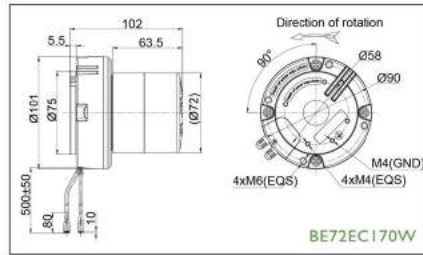
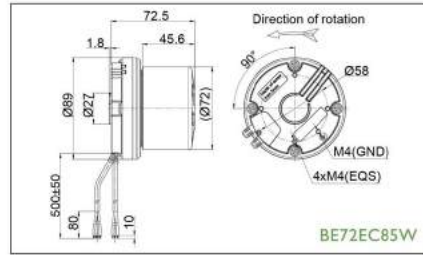
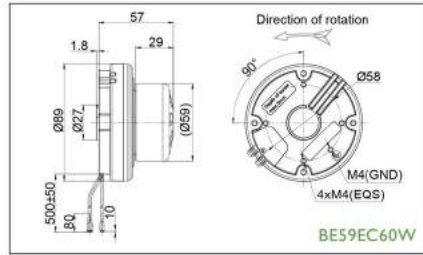

Motor	BE59EC60W	BE72EC85W	BE72EC170W	BE92EC230W	BE102EC700W	BE102EC1300W
Voltage	230V	230V	230V	230V	230V	380V
Frequency	50/60Hz	50/60Hz	50/60Hz	50/60Hz	50/60Hz	50/60Hz
Current	0.47A	0.6A	1.1A	2.0A	3.5A	2.5A
Power	60W	85W	170W	230W	700W	1300W
Speed	400~4450RPM	400~4450RPM	400~4450RPM	400~4450RPM	400~4450RPM	400~4450RPM
Operating Temperature	-25°C~+60°C	-25°C~+60°C	-25°C~+60°C	-25°C~+60°C	-25°C~+60°C	-25°C~+60°C
Wiring Mode	E1	E1	E1	E2	E3	E4

Inlet Rings

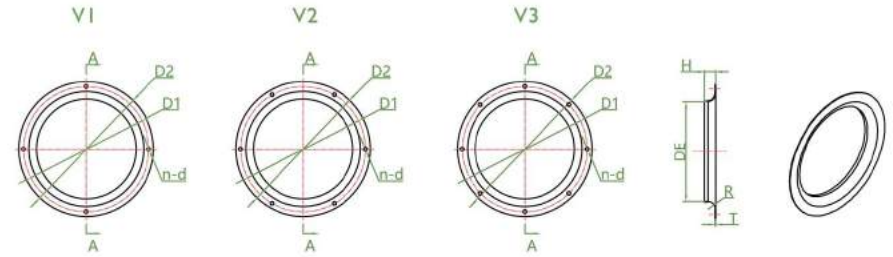

Inlet Rings for Backward Curved Centrifugal Fans

Part Number	Size	Vers.	DE	DI	D2	H	T	n-d
PB3N133Bxx	133	V1	Ø88	Ø118	Ø129	13	1.5	4xØ4.5
PB3N175Bxx	175	V1	Ø123	Ø158	Ø170	14	1.5	4xØ4.5
PB3N190Bxx	190	V1	Ø123	Ø158	Ø170	14	1.5	4xØ4.5
PB3N220Bxx	220	V1	Ø152	Ø245	Ø255	20	1.5	4xØ4.5
PB3N225Bxx	225	V1	Ø145	Ø210	Ø223	27	1.5	4xØ4.5
PB3N250Bxx	250	V1	Ø166	Ø240	Ø255	30	1.5	4xØ4.5
PB3N250Bxx	250	V2	Ø163	Ø259	Ø280	47.5	1.5	6xØ7.0
PB3N280Bxx	280	V1	Ø181	Ø260	Ø280	34	1.5	4xØ4.5
PB3N280Bxx	280	V2	Ø183	Ø286	Ø307	53.5	1.5	6xØ4.5
PB3N310Bxx	310	V1	Ø206	Ø280	Ø300	30	1.5	4xØ4.5
PB3N310Bxx	310	V3	Ø206	Ø320	Ø348	60.5	1.5	8xØ4.5
PB3N355Bxx	355	V3	Ø232	Ø356	Ø382	68.5	1.5	8xØ9.0
PB3N400Bxx	400	V3	Ø260	Ø395	Ø422	77.5	1.5	8xØ11
PB3N450Bxx	450	V2	Ø288	Ø390	Ø413	73.5	1.5	6xØ7.0

Fan Controller

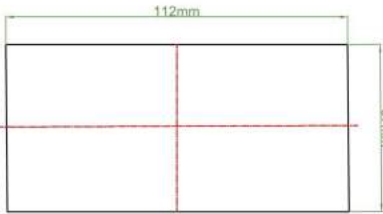

1. Product Introduction

The fan controller is an external Modbus controller, which can realize single control and multiple centralized control. The controller has a built-in Mod-bus communication protocol to control the operation of the fan through the group control system. It is mostly used in FFU group control occasions.

2. The Main Function

The controller controls the fan speed through speed feedback, and uses the principle of speed closed-loop control to control the fan operation. Its main functions are:

- Control the start and stop and speed regulation of each fan through the host;
- Remote centralized control and fault diagnosis can be realized;
- Each control unit module has a settable ID address;
- The current speed and current ID number can be displayed;
- With alarm function.

3. Product Dimensions and Installation Requirements

The controller is powered by the fan without external power supply, the controller is equipped with 2P and 4P quick connect terminals for connection, making the connection simpler and more convenient. The product is designed as a panel installation method, which is convenient for installation and construction. See the figure below for the opening size: 112mm x 57mm

4. Product Application Areas

This product is mainly used in the field of FFU, which can make ordinary EC fans realize group control function, and can effectively solve the problem of group control of ordinary fans.

PS2 intelligent multi-functional touch screen controller

1. General description

PS2-PM2.5/CO₂ controller adopts in touch technology, which is flexible and convenient. There are sensors which can monitor the indoor temperature, humidity, PM2.5 and CO₂ concentration detection function. The output signal of controller can directly control the starting and RPM of the fresh air. It can be widely used in residential, commercial and industrial conditions, and effectively improve the air quality, create a healthy, comfortable, efficient, environmental protection and energy-saving living environment.

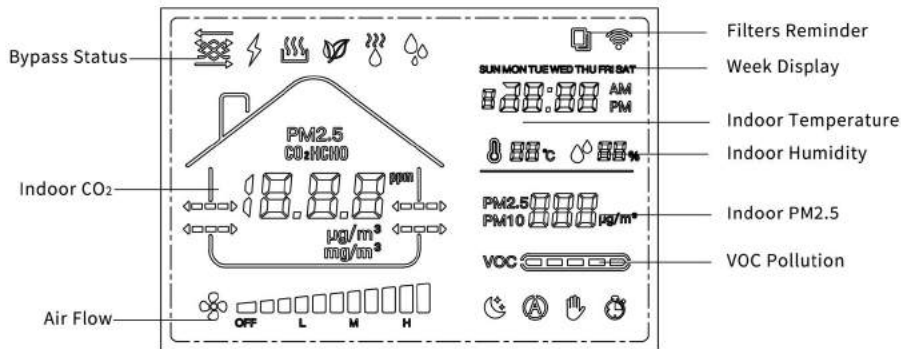

Wiring Diagram

IP55 EI-EC Motor 59.72 (Nominal voltage 115-230VAC)

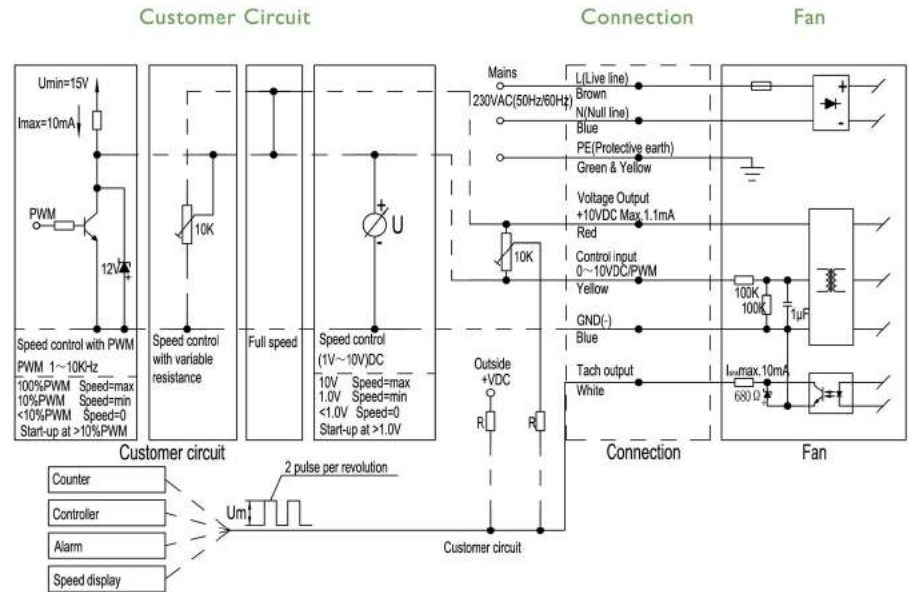

Line I (AC)	Color	Assignment/Function
	Brown	L(Live Line)
	Blue	N(Null Line)
	Green & Yellow	PE(Protective Earth)

Line2(DC)	Color	Assignment/Function
	Red	Voltage Output +10VDC
	Yellow	0-10VDC/PWM
	White	FG
	Blue	GND

Signal	Color	Assignment/Function
L	Brown	Mains 50/60 Hz, phase
N	Blue	Mains 50/60 Hz, neutral
PE	Green & Yellow	Protective Earth

Signal	Color	Assignment/Function
+10VDC	Red	Voltage Output +10VDC max.1.1mA
0-10VDC/PWM	Yellow	Control Input
Tach Output	White	Tach Output:12 puls per revolution
GND	Blue	GND

Wiring Diagram

IP55 E2-EC Motor 92 (Nominal voltage 115-230VAC)

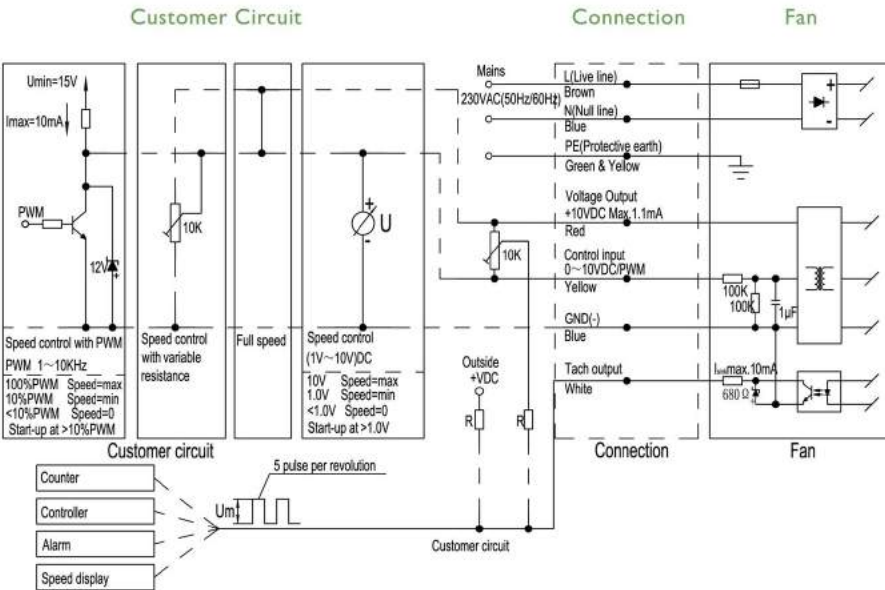

Line1 (AC)	Color	Assignment/Function
L (Live Line)	Brown	
N (Null Line)	Blue	
PE (Protective Earth)	Green & Yellow	

Line2 (DC)	Color	Assignment/Function
+10VDC	Red	Voltage Output +10VDC max.1.1mA
0-10VDC/PWM	Yellow	Control Input
Tach Output	White	Tach Output: 5 puls per revolution
GND	Blue	GND

Signal	Color	Assignment/Function
L	Brown	Mains 50/60 Hz, phase
N	Blue	Mains 50/60 Hz, neutral
PE	Green & Yellow	Protective Earth

Signal	Color	Assignment/Function
+10VDC	Red	Voltage Output +10VDC max.1.1mA
0-10VDC/PWM	Yellow	Control Input
Tach Output	White	Tach Output: 5 puls per revolution
GND	Blue	GND

Wiring Diagram

IP55 E3-EC Motor 102-230VAC-Modbus-Alarm

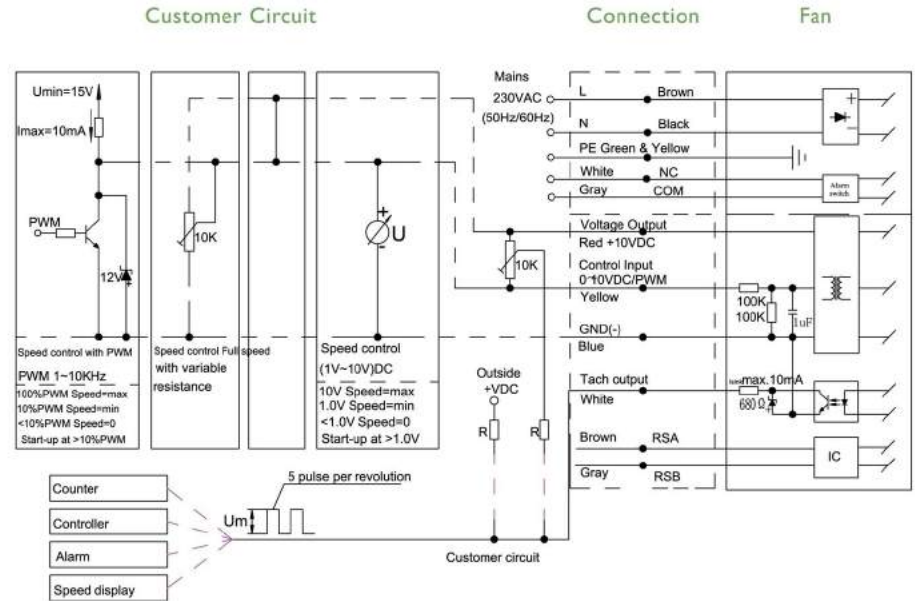

Signal	Color	Assignment/Function
L	Brown	Mains 50/60 Hz, phase
N	Blue	Mains 50/60 Hz, neutral
PE	Green & Yellow	Protective Earth
NC	White	Alarm switch
COM	Gray	Alarm switch

Signal	Color	Assignment/Function
+10VDC	Red	Voltage Output +10VDC max.1.1mA
0-10VDC/PWM	Yellow	Control Input
Tach Output	White	Tach Output: 5 puls per revolution
GND	Blue	GND
RSA	Brown	Modbus- RS485A
RSB	Gray	Modbus- RS485B

Wiring Diagram

IP55 E4-EC Motor 102-380VAC-Modbus-Alarm

Customer Circuit Connection Fan

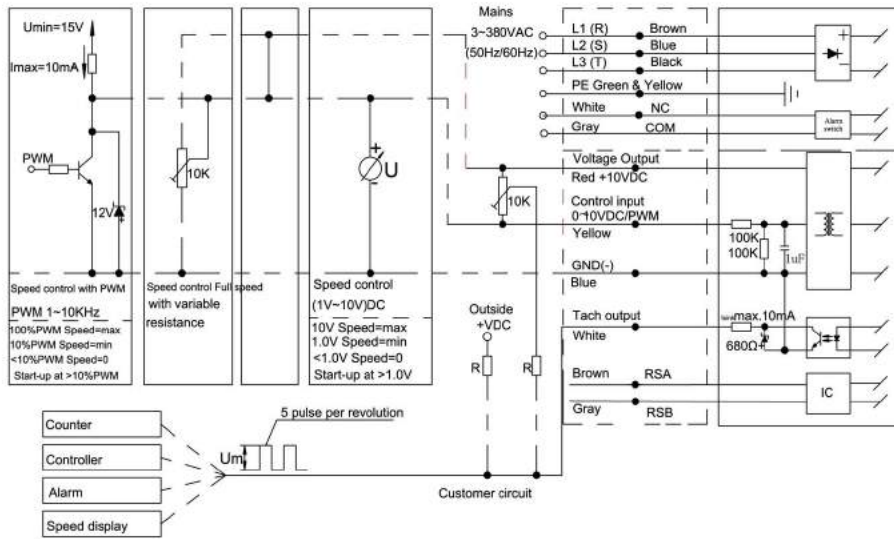

Wiring Diagram

IP55 DI-DC Motor 72 (24,48,85,110,310VDC)

Customer Circuit Connection Fan

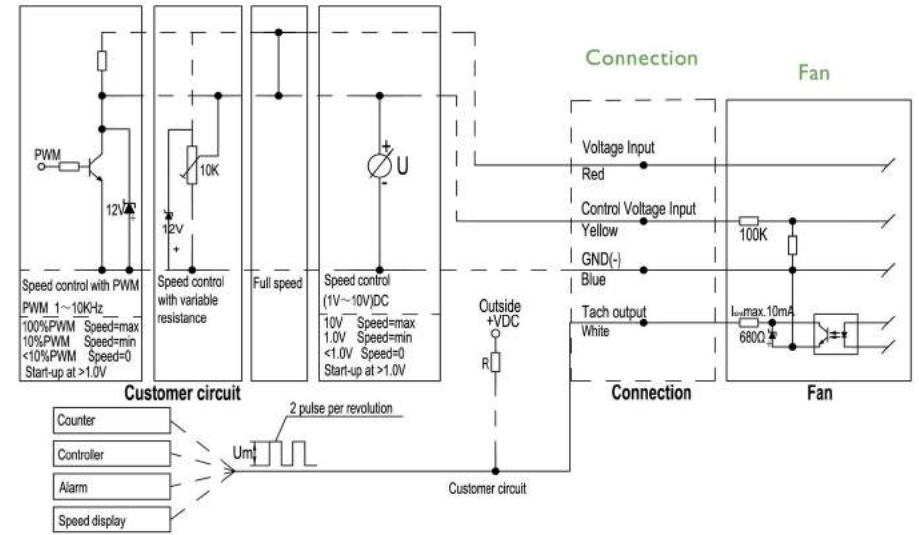

Signal	Color	Assignment/Function
L1	Blue	Mains AC380V 50/60 Hz .R
L2	Brown	Mains AC380V 50/60 Hz .S
L3	Black	Mains AC380V 50/60 Hz .T
PE	Green & Yellow	Protective Earth
NC	White	Alarm switch
COM	Gray	Alarm switch

Signal	Color	Assignment/Function
+10VDC	Red	Voltage Output +10VDC max.1.1mA
0-10VDC/PWM	Yellow	Control Input
Tach Output	White	Tach Output:5 puls per revolution
GND	Blue	GND
RSA	Brown	Modbus-RS485A
RSB	Gray	Modbus-RS485B

Red= +
Yellow= 0-10VDC/PWM
White= FG
Blue= GND

Signal	Color	Assignment/Function
+	Red	Voltage Input
0-10VDC/PWM	Yellow	Control Input
Tach output	White	Tach output:2 puls per revolution
GND	Blue	GND

Effects of installation space

When mounting our product in a rectangular box, air performance might be reduced.

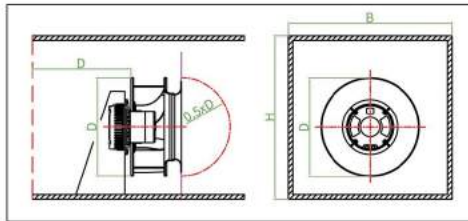

dh = Hydraulic diameter
 Formula: $dh = 2 \times B \times H / (B + H)$
 B = Width of box
 H = Height of box
 D = Outer diameter of the fan

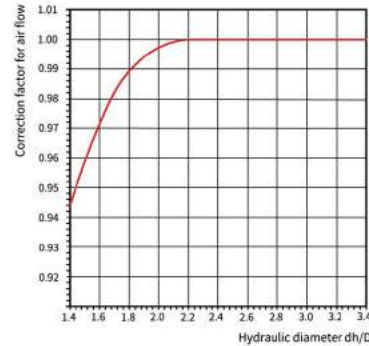

Effects of centrifugal air gap change

The centrifugal air gap between the inlet ring and the impeller cover affects centrifugal fan air flow and operation efficiency. Changes in the size of the inlet ring air gap affects the following curve:

- ①: $s / D = 0.4\%$
- ②: $s / D = 1.0\%$
- ③: $s / D = 1.4\%$

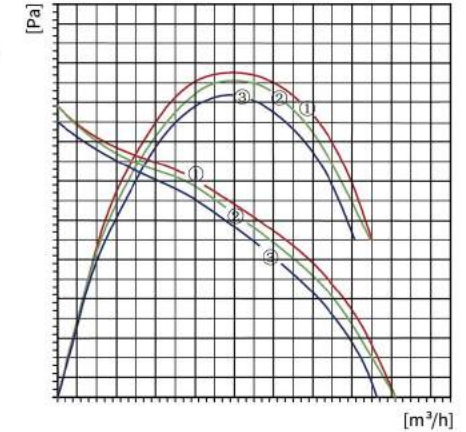
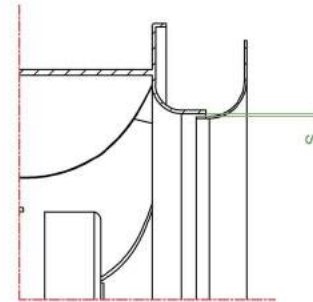

Technical Support

Technical Support

Defining air flow rate for inlet rings with pressure relief

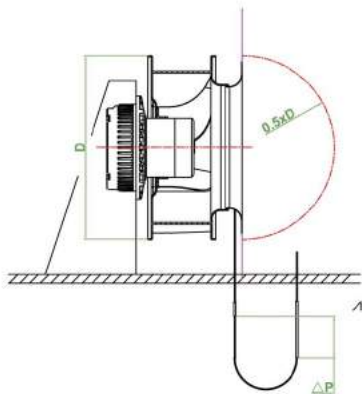

The differential pressure approach compares the static pressure before the inlet nozzle with the static pressure inside the inlet nozzle. Air flow can be calculated on the basis of the differential pressure (difference in pressure of the static pressures) in keeping with the following equation:

$$qv = k \cdot \sqrt{\Delta p} \quad qv \text{ in } [m^3/h] \text{ and } \Delta p \text{ in } [Pa]$$

If constant air flow is to be controlled, then the nozzle pressure has to be kept constant:

$$\Delta p = qv^2 : k^2$$

k takes into account the specific nozzle characteristics. Differences in static pressure are measured in 1/4 measuring point(s) along the circumference of the inlet nozzle. Connection on the customer side is accomplished via a pre-mounted T tube connector. This tube connector is suited for pneumatic hoses with an internal diameter of 4 mm.

Effects of overlapping dimension

The axial overlap between the inlet ring and the impeller cover affects centrifugal fan air flow and operation efficiency. Overlap changes affect the following curve:

- ①: $x / D = 0.6\%$
- ②: $x / D = 0\%$
- ③: $x / D = -0.8\%$

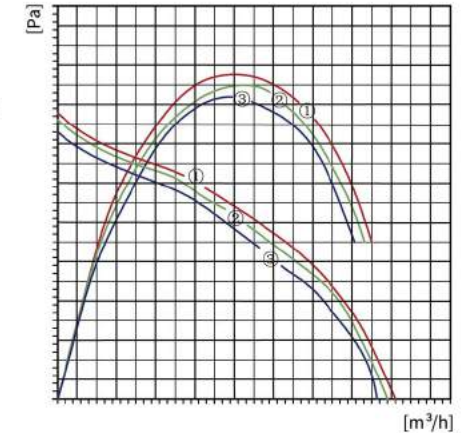
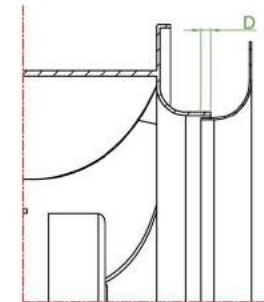

Precision Noise Measuring

Measurement conditions for air and noise measurement

PBM products are measured under the following conditions:

- Axial and diagonal fans in direction of rotation "V" in full nozzle and without guard grille
- Backward curved centrifugal fans, free-running and with inlet nozzle
- Forward curved single and dual inlet centrifugal fans with housing

Noise measurements

All noise measurements are carried out in low-reflective test rooms with reverberant floor. Thus the PBM acoustic test chambers meet the requirements of precision class 1 according to DIN EN ISO 3745. For noise measurement, the fans being tested are placed in a reverberant wall and operated at nominal voltage (for AC, also at nominal frequency) without additional attachments such as the guard grille.

Sound pressure level and sound level

All acoustic values are established according to ISO 13347, DIN 45635 and ISO 3744/3745 to accuracy class 2 and given in A-rated form. When the sound pressure level (L_p) is measured, the microphone is on the intake side of the fan being tested, usually at a distance of 1 m on the fan axis.

To measure the sound power level (L_w), 10 microphones are distributed over an enveloping surface on the intake side of the fan being tested (see graphic). The sound power level measured can be roughly calculated from the sound pressure level by adding 7 dB.

Measuring configuration as per ISO 13347-3 respectively DIN 45635-38:10 measuring points

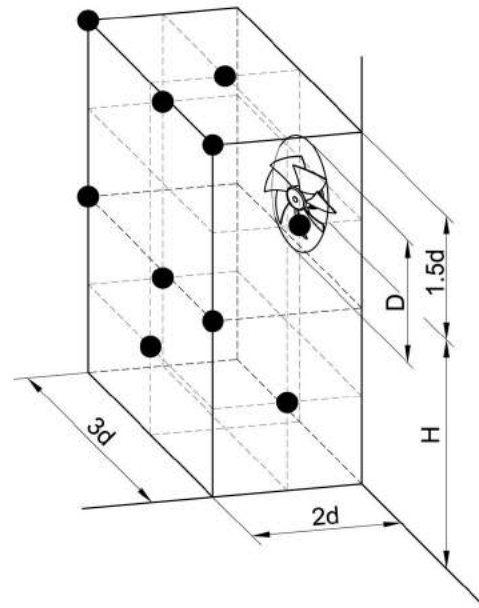

$d \geq D$
 $H = 1.5d \dots 4.5d$
 Measurement area $S = 6d^2 + 7d(H + 1.5d)$

Combined level of multiple same-level sound sources

Adding 2 noise sources with the same level results in a level increase of approx. 3 dB. The noise characteristics of multiple identical fans can be determined in advance based on the noise values specified in the data sheet. This is shown in the diagram opposite.

Example: 8 PCS PG3N400B2E-MZ0 axial fans are on a condenser. According to the data sheet, the sound pressure level of a fan is approximately 68 dB(A). The level increase measured from the diagram is 9 dB. Thus the overall sound level of the installation can be expected to be 77 dB(A).

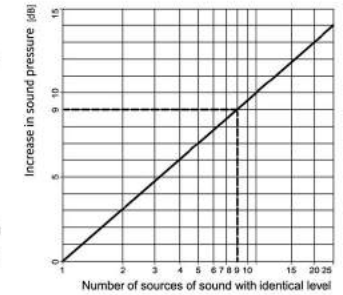

Combined level of two different-level sound sources

The acoustic performance of two different fans can be predetermined based on the sound levels given in the data sheet. This is shown in the diagram opposite.

Example: There is an axial fan PG3N400B2E-MZ0 with a sound pressure level of 68 dB(A) at the operating point and an axial fan PG3N400B2E-ZW5 with 73 dB(A) in a ventilation unit. The level difference is 5 dB. The level increase can now be read in the diagram as approx. 1.2 dB. This means that the overall sound level of the unit can be expected to be 74.2 dB(A).

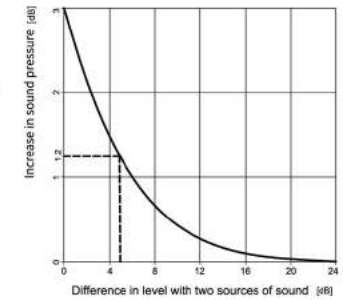

Distance laws

Sound power level is independent from distance to the sound source. In contrast to this, sound pressure level decreases the further away the noise source is. The adjacent diagram shows the decrease in level under far sound field conditions. Far sound field conditions apply whenever the distance between microphone and fan is big when compared to fan diameter and wavelength to be considered. For more information on far sound field, please consult the relevant literature on this complex topic. Per doubling of distance, the level in the far sound field decreases by 6 dB. In the near field of the fan, other correlations apply and the decrease in levels can be considerably smaller. The following example only applies to far sound field conditions and can vary strongly depending on the installation effects.

Example: An axial fan PG3N400B2E-MZ0, a sound pressure level of 68 dB(A) was measured at a distance of 1 m. According to the adjacent diagram, at a distance of 10 m we would get a reduction by 19.5 dB, i.e. a sound pressure level of 48.5 dB(A).

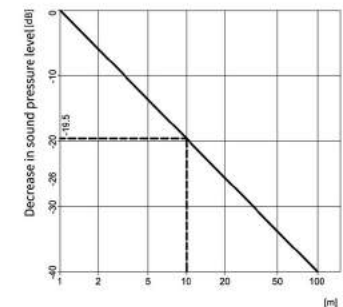

How to Choose Fans Correctly

All need to use is the electrical machinery and electronic products project engineer which the ventilator radiates, a specific system that radiates the needed amount of air flow is a must, the amount of air flow is decided by the understanding system power consumption and the ability of carrying off the enough quantity of heat. Try to prevent the system superheat situation. The fact demonstrated that the system service life can be reduced as a result of the cooling system insufficiency, therefore project engineer also should understand system sales volume and price, possibly because the system service life symbol user did not anticipate drops. If you'd like to choose the correct well ventilated module, the following goals need to be considered:

- Best air transport efficiency
- Smallest suitable size
- Lowest noise
- Smallest power consumption
- Biggest margin of safety and service life
- Reasonable total cost

So following three steps to correctly choose radiation fan or the drum ventilator, help you achieve the above goals:

Total cooling demand, first must understand three key aspects by obtaining the cooling demand the quantity of heat that must be transformed(temperature DT). Counterbalance transformation quantity of heat wattage(W). The detachment quantity of heat needs amount of wind(CFM).

The total cooling demand regarding of system operating effectively is really important. The effective system operation must provide the Ideal operation condition, enables in all systems the module to display the biggest function and the longest service life.

The following available ways are generally used when choosing the ventilator motor:

- Figures out quantity of heat which the equipment interior produces
- Decided the equipment interior can permit temperature rise scope
- Amount of air flow needs which from the equation computation
- If the known system equipment interior heat dissipating capacity and the permission total temperature rise quantity, may obtain the amount of wind which is for the cooling equipment needs.

Following into basic hot transformation equation:

$$H = C_p \times W \times \Delta T$$

in which: H = Hot transformation quantity

C_p = Air specific heat

ΔT = In the equipment rises temperature

W = Air flow weight

We know ($W = CFM \times D$) in which D = is mad the density after the substitution, We obtain, Conversion factors

With the substitution sea level air specific heat and the density, may obtain following radiation equation:

$$CFM = 3160 \times KW / \Delta T$$

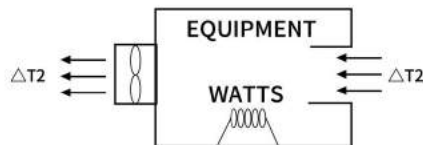

Eg(a): The equipment Internal consumption electric power is 500W, the temperature difference is 20 degrees Fahrenheit, please see the computed result below:

$$Q = \frac{3.16 \times 500(W)}{20} = 79CFM \quad \text{or} \quad Q = \frac{0.09 \times 500(W)}{20} = 2.25m^3/Min$$

(b) The equipment internal consumption electric power is 500W, the temperature difference is 10 degrees centigrade:

$$Q = \frac{1.76 \times 500(W)}{20} = 88CFM \quad \text{or} \quad Q = \frac{0.05 \times 500(W)}{20} = 2.5m^3/Min$$

Amount of Wind Conversion Table

CMS	CMM	L/s	L/min	CMH	CFS	CFM
m ³ /s	m ³ /min	L/s	L/min	m ³ /h	ft ³ /s	ft ³ /min
1	60	1x10 ³	6x10 ⁴	3.6x10 ³	35.30	2.118x10 ³
0.0167	1	460	1x10 ³	60	0.5885	35.30
0.001	0.06	1	60	3.60	0.0353	2.12
1.67x10 ⁻⁵	0.001	0.0167	1	0.06	5.88x10 ⁻⁴	0.0353
2.77x10 ⁻⁴	0.0167	0.277	16.7	1	9.81x10 ⁻³	0.5885
0.0283	1.698	460	1.69x10 ³	101.9	1	60
4.7x10 ⁻⁴	0.0283	0.47	28.3	1.698	0.0167	1

Static pressure conversion table

Pa	Bar	Torr	kgf/cm ³	mmH ₂ O	inHg	psi
N/m ²	Bar	mmHg	kgf/cm ³	mmH ₂ O	inHg	lb/in ²
1	1x10 ⁻⁵	7.501x10 ⁻³	1.02x10 ⁻⁵	0.1021	2.953x10 ⁻⁴	1.45x10 ⁻⁴
1x10 ⁵	1	750.10	1.02	1.02x10 ⁴	29.53	14.50
133.30	1.33x10 ⁻³	1	1.359x10 ⁻³	13.61	0.03937	0.01934
9.807x10 ⁴	0.9807	735.5	1	1.001x10 ⁴	28.96	14.22
9.807	9.807x10 ⁻⁵	0.07348	9.96x10 ⁻⁵	1	2.89x10 ⁻³	1.42x10 ⁻³
3.386x10 ³	0.03386	25.4	0.03453	345.6	1	0.4912
6.895x10 ³	1.013	760	1.033	1.034x10 ⁴	29.92	14.7

The following available ways are generally used when choosing the ventilator motor:

- Figures out quantity of heat which the equipment interior produces
- Decided the equipment interior can permit temperature rise scope
- Amount of air flow needs which from the equation computation
- If the known system equipment interior heat dissipating capacity and the permission total temperature rise quantity, may obtain the amount of air flow which is for the cooling equipment needs.

Fan Selection Guide



In order to provide you with more considerate fan selection and technical solution services, please provide your demand information in the following table as much as possible:

Note: The Red * marked is required.		Date	
Project Name		* Client Name	
* Applied to Which Products or Industries		Special Working Conditions to be Reminded	
Fan Mounting Space Size (LxWxH)	mm	Motor Type	
* Blade Type and Materials		* Impeller Size (LxWxH)	mm

Is it possible to provide 《Fan Technical Requirements List 》 or replaced fan specification or replaced fan brand & model number?

Fan's Key Technical Requirements	Key Parameters	P/Q	Replaced Fan Brand	Replaced Fan Model Number	Photo of Replaced Fan Name Plate

Key Technical Parameter Information For Fan Selection

* Rated Voltage (V)		Max. Current (A)		Frequency (HZ)	
Rated Power(W)		Motor Output Power (W)		Bearing Type	
* Max. Airflow (M ³ /H)		* Max. Air Pressure (Pa)		* Speed (RPM)	
Operation Point's Air Flow & Air Pressure		Max. Operating Temperature (°C)		Rotation or Air Flow Direction	
* Expected Sound Level (dBA)		Water and Dust Protection Class (IPXX)		Isulation Class	
Motor Operating Protections		Speed Control Type		Certificates	
Operating Voltage Range (V)		Wire Length and Connector Requirements		Wiring Mode	
Fan Efficiency (η)		Motor Efficiency (η)		Fan Operation Control	

Key Commercial Requirements

Total Quantity Demand		Quantity and Date for the First Order	
Quantity of Sample		Sample Demand Time	
Packing Demand		Type of Shipping	
* Recipient's Name and Mobile Number		* Detail Receiving Address	

Client's Other Requirements:

Such as: non-standard fan size (mm), special installation requirements, special working and operating environment, etc