

DC Axial Fan $\varnothing 180 \times 70 \text{mm}$

Axial Fans

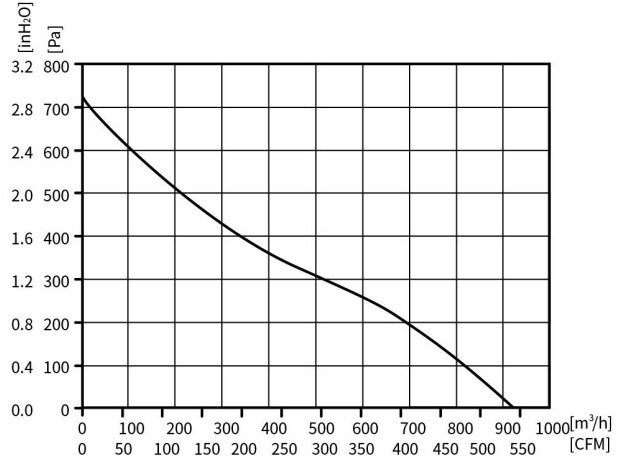

Motor Type DC BRUSHLESS EXTERNAL ROTOR MOTOR	Speed Control 0~10VDC/PWM	Protection Type IP44	Insulation Class B	Operating Temperature -25°C~+60°C	Weight 1.8KG	Wiring Mode D2
---	------------------------------	-------------------------	-----------------------	--------------------------------------	-----------------	-------------------

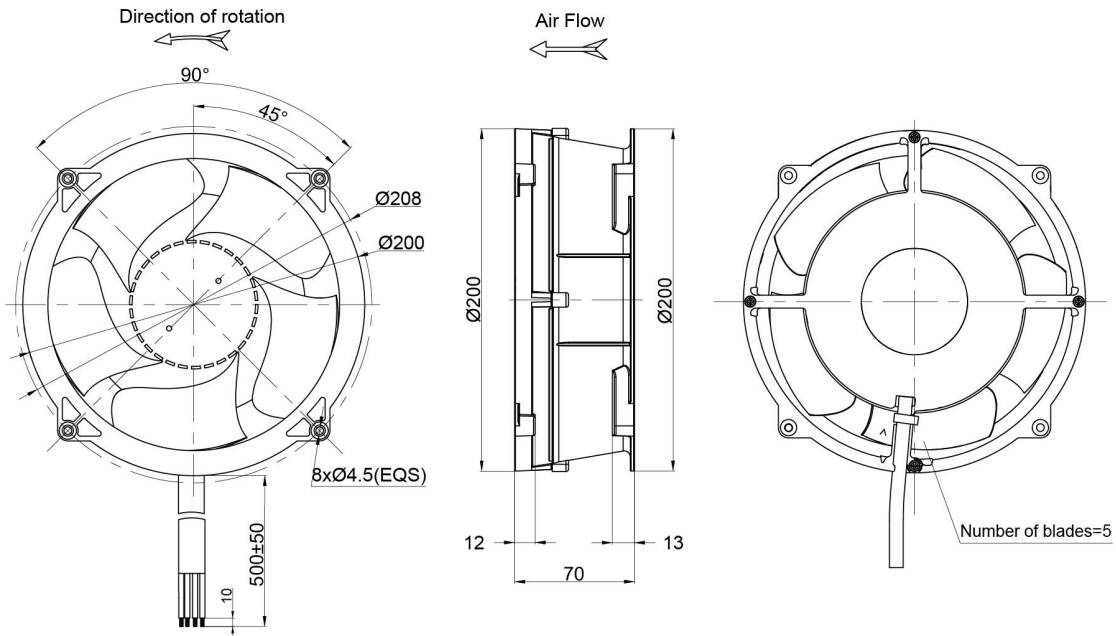

Model	Motor	Bearing System	Rated Voltage	Operating Voltage	Rated Current	Rated Power	Rated Speed	Air Flow	Air Pressure	Sound Level
Part No.	Type	B/S	VDC	VDC	A	W	RPM	M ³ /H	Pa	dB(A)
PA3N180B24H	BE92DC	BALL	24	16~28	4.2	100.8	4500	925	709	68
PA3N180B48H	BE92DC	BALL	48	36~57	2.1	100.8	4500	925	709	68

DC Axial Fan $\varnothing 200 \times 80 \text{mm}$

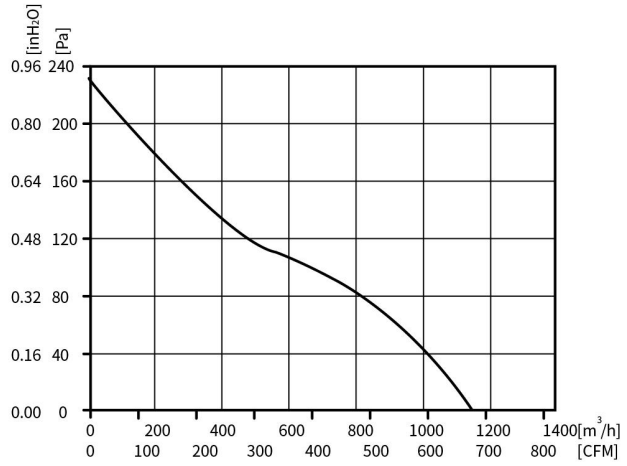

Axial Fans

Motor Type DC BRUSHLESS EXTERNAL ROTOR MOTOR	Speed Control 0~10VDC/PWM	Protection Type IP44	Insulation Class B	Operating Temperature -25°C ~ +60°C	Weight 2.4KG	Wiring Mode D2
---	------------------------------	-------------------------	-----------------------	--	-----------------	-------------------

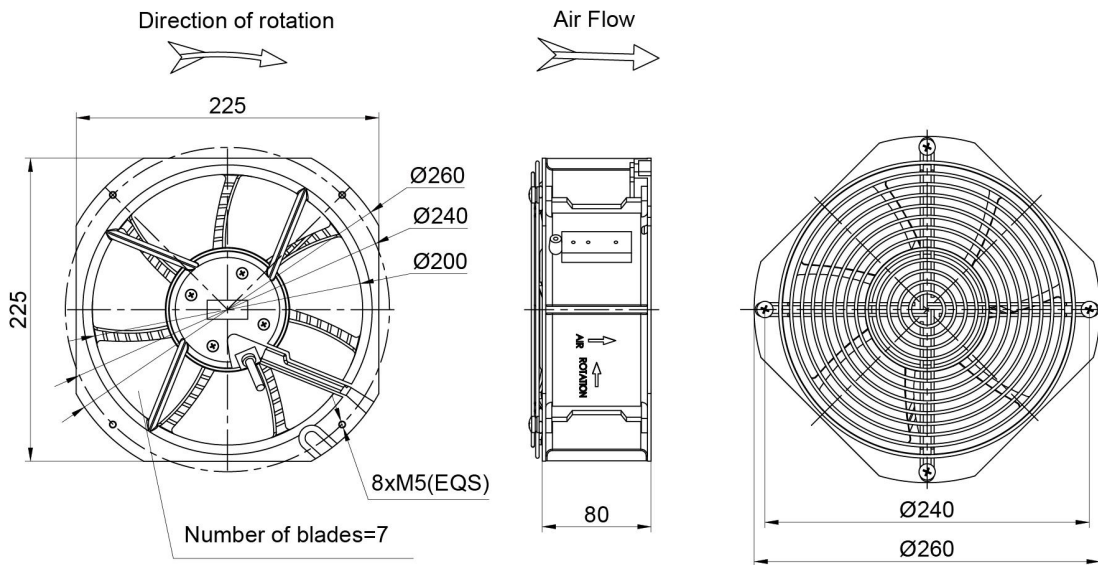

Model	Motor	Bearing System	Rated Voltage	Operating Voltage	Rated Current	Rated Power	Rated Speed	Air Flow	Air Pressure	Sound Level
Part No.	Type	B/S	VDC	VDC	A	W	RPM	M ³ /H	Pa	dB(A)
PA3N200B24H	BE92DC	BALL	24	16~28	1.8	43.2	2750	1150	236	60
PA3N200B48H	BE92DC	BALL	48	36~57	0.9	43.2	2750	1150	236	60

DC Axial Fan $\varnothing 215 \times 89 \text{mm}$

Axial Fans

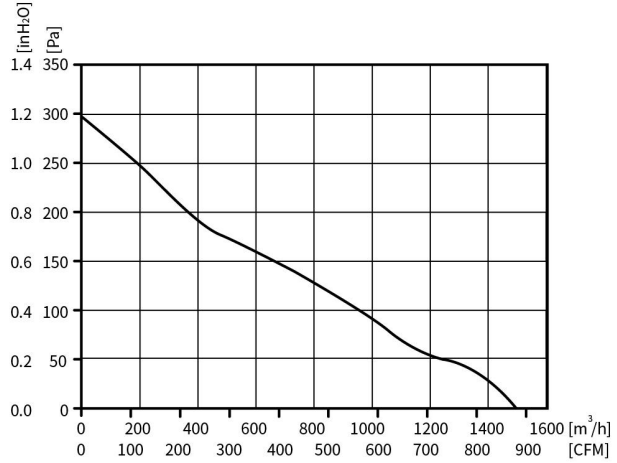

Motor Type DC BRUSHLESS EXTERNAL ROTOR MOTOR	Speed Control 0~10VDC/PWM	Protection Type IP44	Insulation Class B	Operating Temperature -25°C~+60°C	Weight 2.1KG	Wiring Mode D2
---	------------------------------	-------------------------	-----------------------	--------------------------------------	-----------------	-------------------

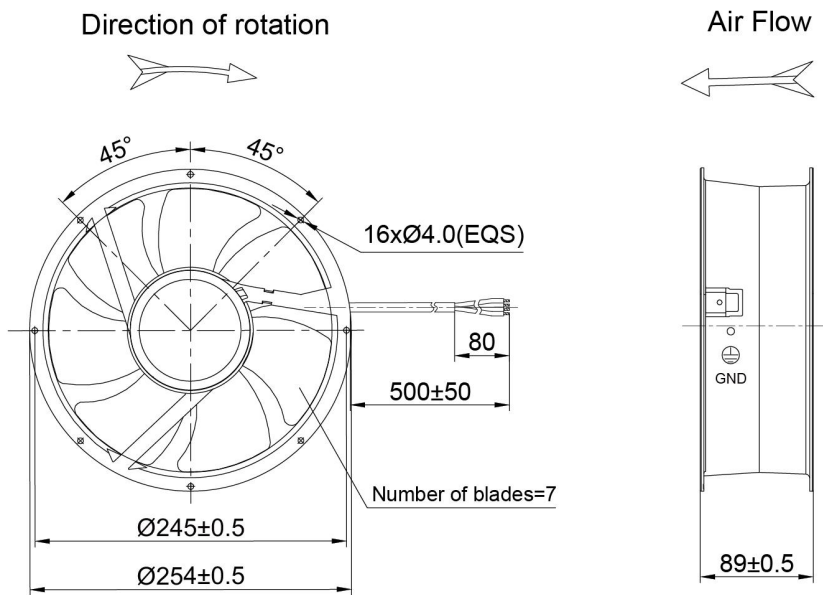

Model	Motor	Bearing System	Rated Voltage	Operating Voltage	Rated Current	Rated Power	Rated Speed	Air Flow	Air Pressure	Sound Level
Part No.	Type	B/S	VDC	VDC	A	W	RPM	M ³ /H	Pa	dB(A)
PA3N215B24U	BE92DC	BALL	24	16~28	1.9	91	3100	1512	294	69
PA3N215B48U	BE92DC	BALL	48	36~57	0.95	91	3100	1512	294	69

DC Axial Fan $\varnothing 215 \times 89.8 \text{mm}$

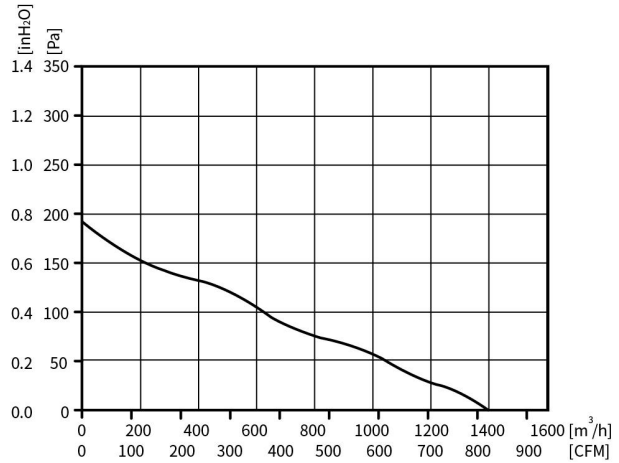

Axial Fans

Motor Type DC BRUSHLESS EXTERNAL ROTOR MOTOR	Speed Control 0~10VDC/PWM	Protection Type IP44	Insulation Class B	Operating Temperature -25°C~+60°C	Weight 2.1KG	Wiring Mode D1
---	------------------------------	-------------------------	-----------------------	--------------------------------------	-----------------	-------------------

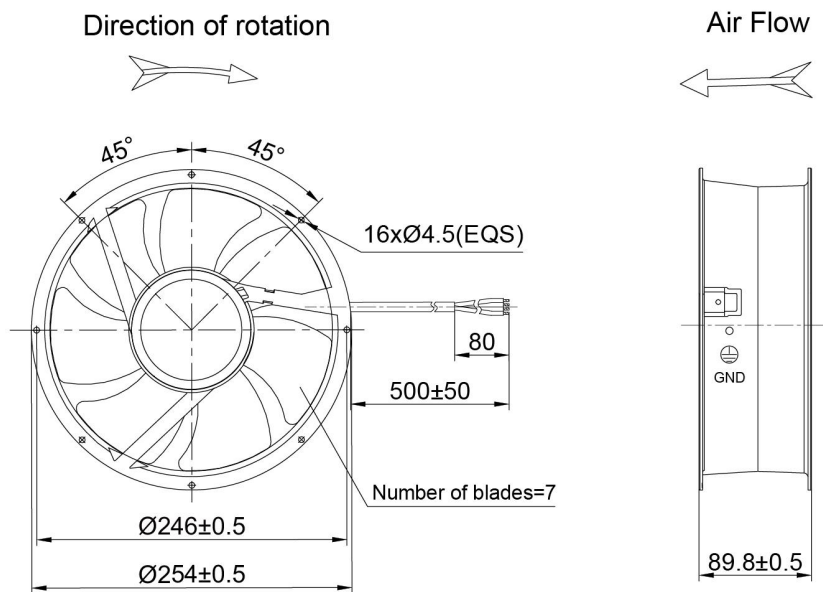

Model Part No.	Motor Type	Bearing System B/S	Rated Voltage VDC	Operating Voltage VDC	Rated Current A	Rated Power W	Rated Speed RPM	Air Flow M ³ /H	Air Pressure Pa	Sound Level dB(A)
PA3N215B24H	BE72DC	BALL	24	16~28	1.5	72	2500	1410	190	65
PA3N215B48H	BE72DC	BALL	48	36~57	0.75	72	2500	1410	190	65

DC Axial Fan $\varnothing 215 \times 89 \text{mm}$

Axial Fans

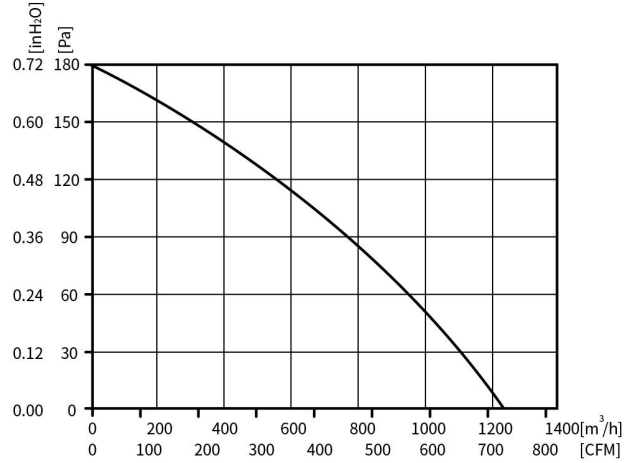

Motor Type DC BRUSHLESS EXTERNAL ROTOR MOTOR	Speed Control 0~10VDC/PWM	Protection Type IP44	Insulation Class B	Operating Temperature -25°C~+60°C	Weight 2.8KG	Wiring Mode D2
---	------------------------------	-------------------------	-----------------------	--------------------------------------	-----------------	-------------------

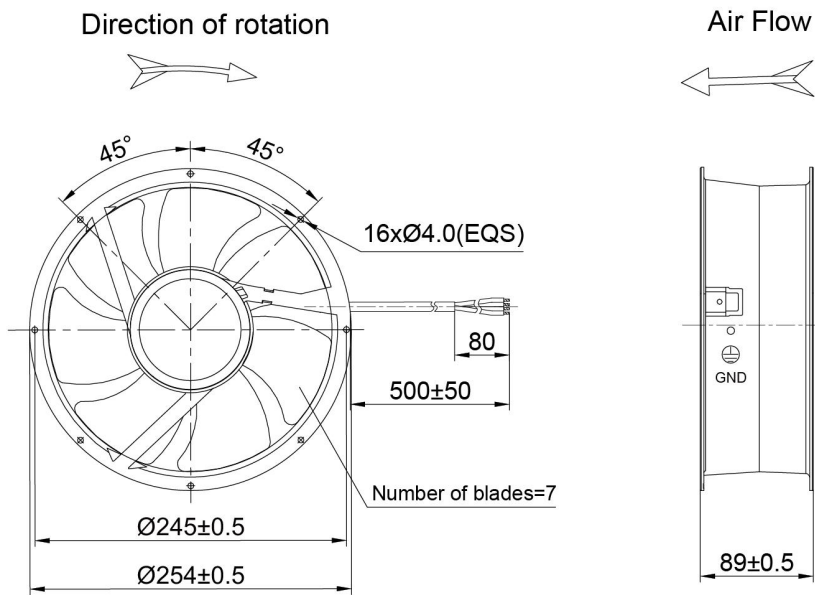

Model	Motor	Bearing System	Rated Voltage	Operating Voltage	Rated Current	Rated Power	Rated Speed	Air Flow	Air Pressure	Sound Level
Part No.	Type	B/S	VDC	VDC	A	W	RPM	M ³ /H	Pa	dB(A)
PA3N215B24M	BE92DC	BALL	24	16~28	2.6	62.4	2000	1230	180	62
PA3N215B48M	BE92DC	BALL	48	36~57	1.3	62.4	2000	1230	180	62

DC Axial Fan $\varnothing 250 \times 80 \text{mm}$

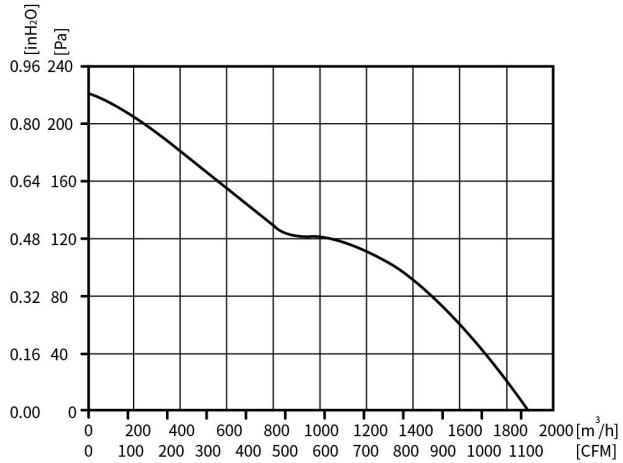

Axial Fans

Motor Type DC BRUSHLESS EXTERNAL ROTOR MOTOR	Speed Control 0~10VDC/PWM	Protection Type IP44	Insulation Class B	Operating Temperature -25°C~+60°C	Weight 2.5KG	Wiring Mode D2
---	------------------------------	-------------------------	-----------------------	--------------------------------------	-----------------	-------------------

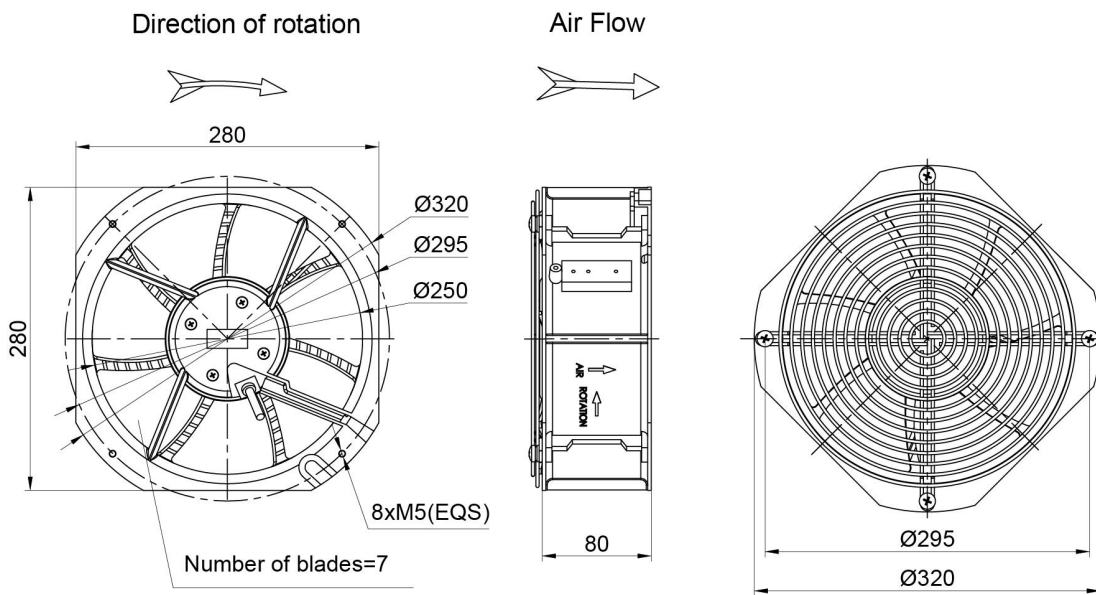

Model	Motor	Bearing System	Rated Voltage	Operating Voltage	Rated Current	Rated Power	Rated Speed	Air Flow	Air Pressure	Sound Level
Part No.	Type	B/S	VDC	VDC	A	W	RPM	M ³ /H	Pa	dB(A)
PA3N250B24H	BE92DC	BALL	24	16~28	4.8	115.2	2750	1900	220	69
PA3N250B48H	BE92DC	BALL	48	36~57	2.4	115.2	2750	1900	220	69

DC Axial Fan $\varnothing 300 \times 90 \text{mm}$

Axial Fans

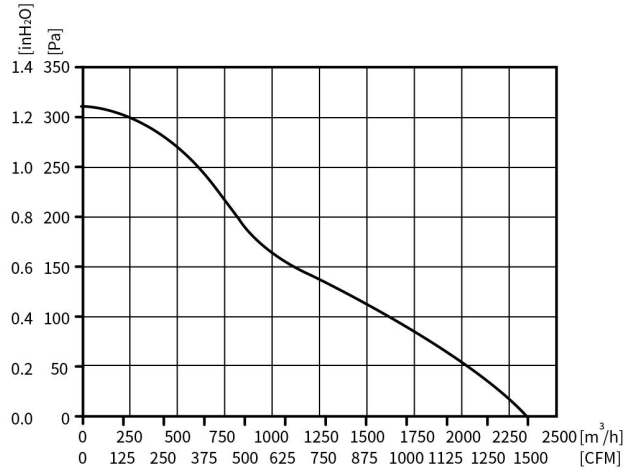

Motor Type DC BRUSHLESS EXTERNAL ROTOR MOTOR	Speed Control 0~10VDC/PWM	Protection Type IP44	Insulation Class B	Operating Temperature -25°C~+60°C	Weight 3.5KG	Wiring Mode D2
---	------------------------------	-------------------------	-----------------------	--------------------------------------	-----------------	-------------------

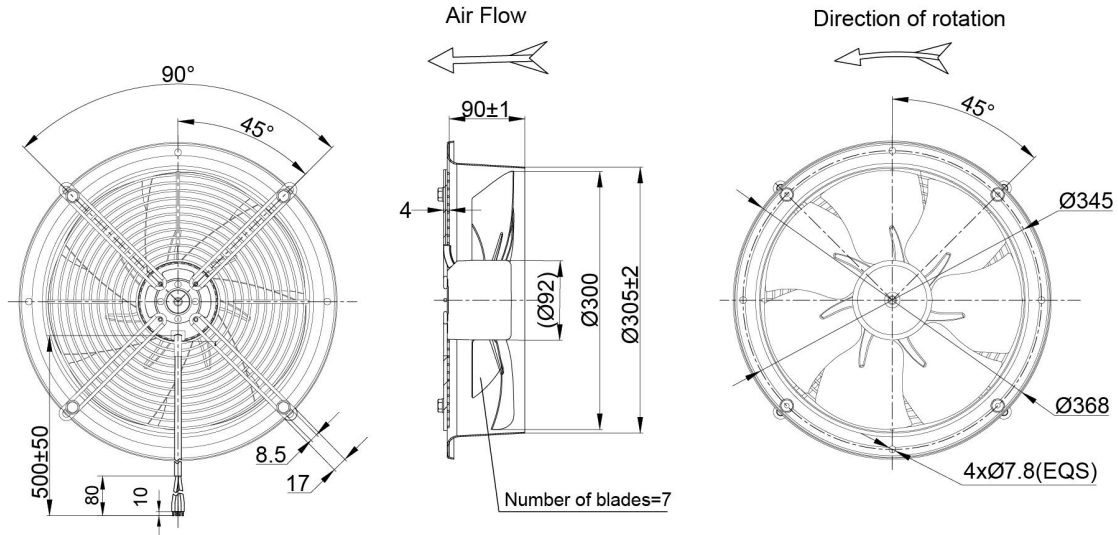

Model	Motor	Bearing System	Rated Voltage	Operating Voltage	Rated Current	Rated Power	Rated Speed	Air Flow	Air Pressure	Sound Level
Part No.	Type	B/S	VDC	VDC	A	W	RPM	M ³ /H	Pa	dB(A)
PW3N300B24H	BE92DC	BALL	24	16~28	6.5	156	2200	2330	316	65
PW3N300B48H	BE92DC	BALL	48	36~57	3.25	156	2200	2330	316	65

DC Axial Fan $\varnothing 400 \times 140 \text{mm}$

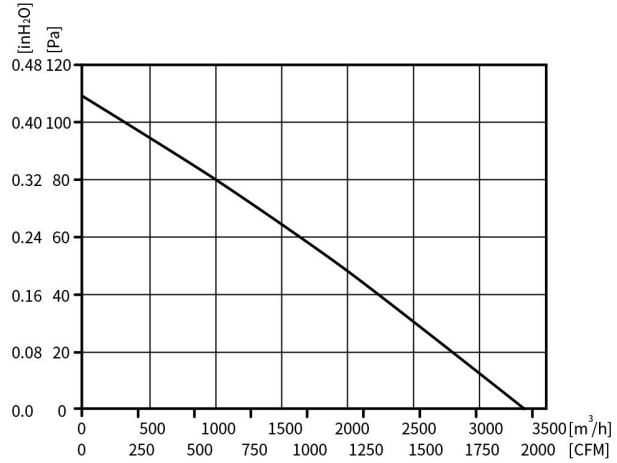

Axial Fans

Motor Type DC BRUSHLESS EXTERNAL ROTOR MOTOR	Speed Control 0~10VDC/PWM	Protection Type IP44	Insulation Class B	Operating Temperature -25°C~+60°C	Weight 5.1KG	Wiring Mode D3
---	------------------------------	-------------------------	-----------------------	--------------------------------------	-----------------	-------------------

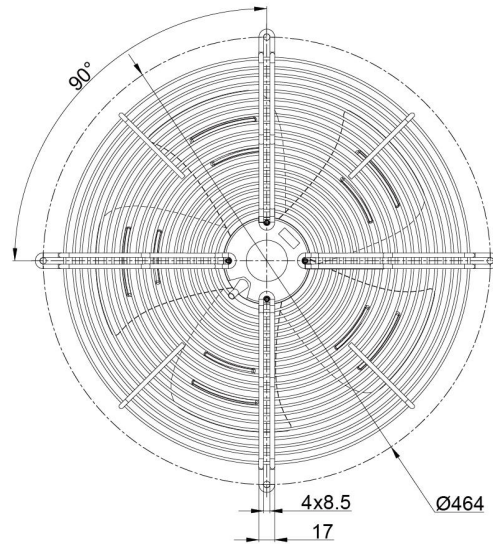
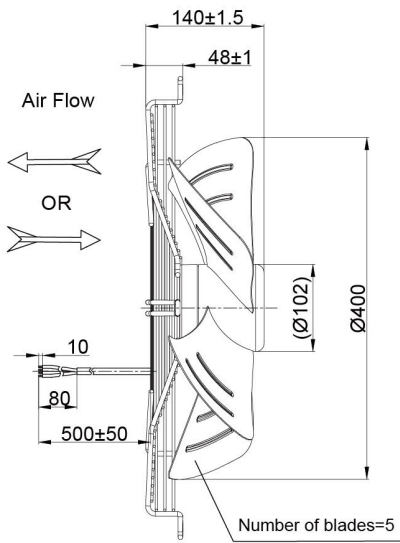

Model	Motor	Bearing System	Rated Voltage	Operating Voltage	Rated Current	Rated Power	Rated Speed	Air Flow	Air Pressure	Sound Level
Part No.	Type	B/S	VDC	VDC	A	W	RPM	M ³ /H	Pa	dB(A)
PG3N400B24M	BE102DC	BALL	24	16~28	6.4	153.6	1100	3363	108	58
PG3N400B48M	BE102DC	BALL	48	36~57	3.2	153.6	1100	3363	108	58

DC Axial Fan $\varnothing 450 \times 124.5 \text{mm}$

Axial Fans

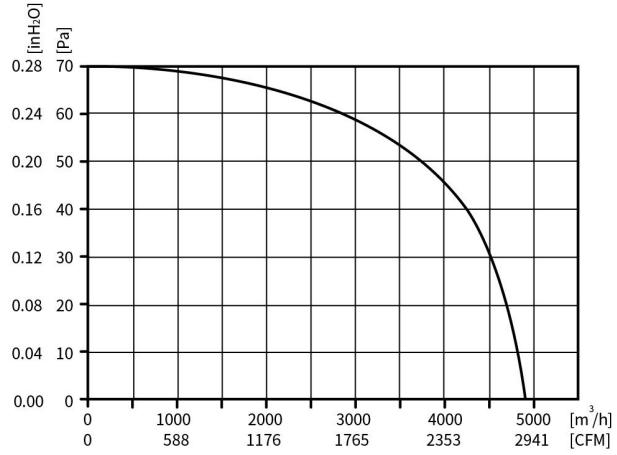

Motor Type DC BRUSHLESS EXTERNAL ROTOR MOTOR	Speed Control 0~10VDC/PWM	Protection Type IP44	Insulation Class B	Operating Temperature -25°C~+60°C	Weight 6.3KG	Wiring Mode D3
---	------------------------------	-------------------------	-----------------------	--------------------------------------	-----------------	-------------------

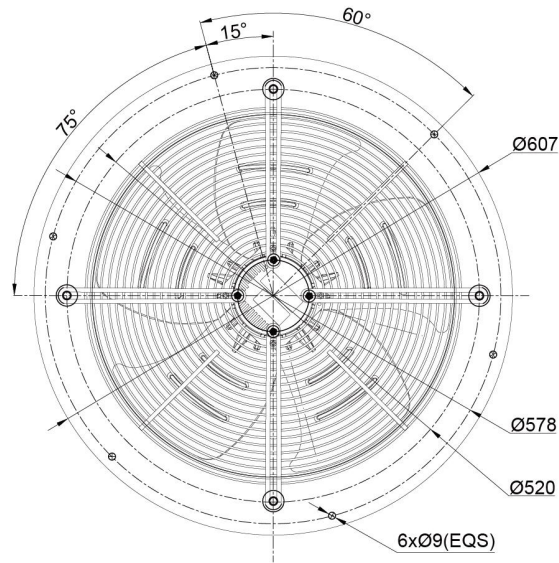
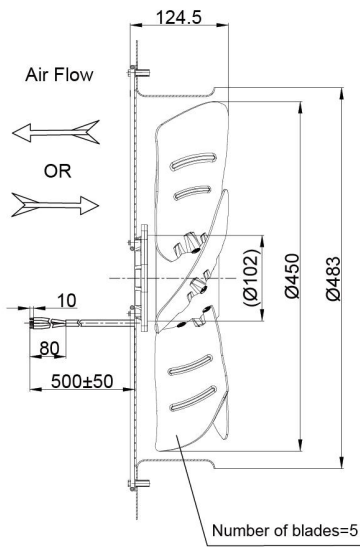

Model	Motor	Bearing System	Rated Voltage	Operating Voltage	Rated Current	Rated Power	Rated Speed	Air Flow	Air Pressure	Sound Level
Part No.	Type	B/S	VDC	VDC	A	W	RPM	M ³ /H	Pa	dB(A)
PG3N450B24M	BE102DC	BALL	24	16~28	6.6	160	1050	4800	70	60
PG3N450B48M	BE102DC	BALL	48	36~57	3.3	160	1050	4800	70	60